

QuickStart Presentation

CDL Gateway Modular Controller

Topics Covered

1. MonicoView™ Software
2. Selecting the Hardware
3. Extracting/Downloading a Database
4. Setting the Modbus Drop number
5. Setting the IP Address of the Gateway
6. Setting the Target IP Address to your PLC
7. CDL Connections
8. Modbus Connections
9. Am I Getting Data?

MonicoView™ is the Gateway configuration package from Monico Inc. MonicoView™ is designed to provide quick and easy access to the features of the Gateway series of operator panels, while still allowing the advanced user to take advantage of high-end features, such as MonicoView's unique programming support. The latest version can be downloaded from the Support page of our website at:

<http://www.monicoinc.com/support.php>

Location of MonicoView™ download on our Support page:



[Home](#) | [About Us](#) | [Info](#) | [Products](#) | [Quotation](#) | [Blog](#) | [Support](#) | [Contact](#)

Support

CDL Gateway™

- [CDL Gateway™ Overview Data Sheet](#)
- [CDL Gateway™ Modbus Version](#)
- [CDL Gateway™ Allen Bradley ControlLogix Version](#)
- [CDL Gateway™ Allen Bradley SLC Version](#)
- [CDL Gateway™ GE Fanuc Version](#)
- [CDL Gateway™ Siemens PLC Version](#)
- [CDL Gateway™ BACnet Version](#)
- [CDL Gateway PLUS™](#)
- [CDL Gateway™ HMI Overview Data Sheet](#)
- [CDL Gateway™ Color Touch Screen HMI](#)
- [CDL Gateway™ Operations Manual](#)
- [CDL Gateway™ Combined Data Map](#)
- [CDL Option Card Data Sheet](#)
- [Gateway PLUS Data Sheet](#)
- [Digital I/O Module Data Sheet](#)
- [Analog I/O Modules Data Sheet](#)

MonicoView™ Programming Software-CDL and Custom Protocol Gateways

- [MonicoView™ Programmer Build 522C](#)
- [MonicoView™ Programmer User Manual](#)
- [Windows Vista USB Drivers for MonicoView™](#)

Custom Protocol Gateway™

- [Custom Protocol Gateway™](#)
- [Profibus Option Card Data Sheet](#)
- [DeviceNet Option Card Data Sheet](#)
- [Serial Port Option Card Data Sheet](#)
- [Digital I/O Module Data Sheet](#)
- [Analog I/O Modules Data Sheet](#)

It is important that you use the latest version of MonicoView™ before starting the configuration process. To determine your version, start MonicoView™, click on “Help” and then “About.” Look for the line I have circled in the image below.

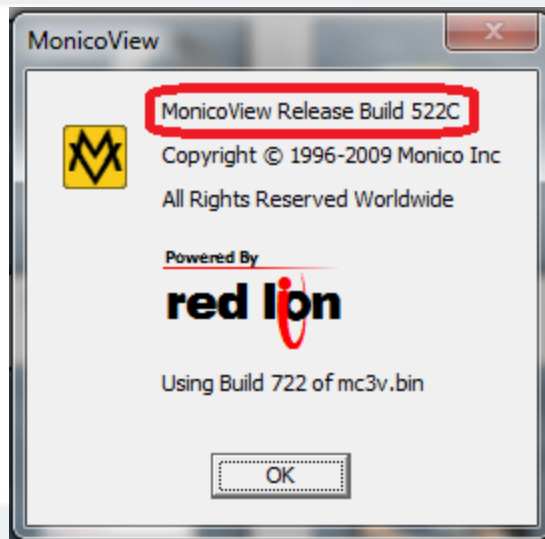

In the illustration above the version of MonicoView is 522C.

We have 2 Product families: Gateways & HMIs

CDL Gateway PLUS™(GT) series



The Monico CDL Gateway PLUS™ retains all the communications and protocol conversion capabilities of the CDL Gateway™, while adding several valuable features including real-time data logging, Mail Server, Sync Server, Time Manager, and Virtual HMI Web Server.

The Monico CDL Gateway PLUS™ provides the ability to remotely monitor and control industrial engines, generators, compressors and other equipment from a remote location. The email server is programmable to send email and SMS alerts to notify personnel of Warnings and Shutdowns.

The real-time data logging feature has proven extremely valuable for troubleshooting tough problems that require continuous real-time data. It will accept up to a 2 GB Flash card that can store log files for 80 parameters every three seconds for 200 days. These log files are stored in raw and CSV formats for easy import into Microsoft Excel. The trend and historical data provided by this feature are extremely important for high value industrial equipment. Even if you have a high bandwidth SCADA system, the on-board data logging can serve as a critical backup in case of communications link failure.

We have 2 Product families: Gateways & HMIs

CDL Gateway PLUS™ (GT) series cont'd



The Virtual HMI Web Server allows remote access to your equipment with only Internet Explorer. The web pages can be custom built or you can use our pre-configured pages for basic data. Our free MonicoView™ software can be used to create your own custom pages or to modify and customize the factory default pages.

Features Include:

- Pre-configured solution that provides basic HMI screens over the internet
- Customizable with our free software, MonicoView™
- SMTP Server and SMS Server for email notification of alarms and shutdowns
- Accepts up to 2 GB Compact Flash memory card that will store up to 200 days worth of data in raw and CSV formats.
- Sync Server to copy data log files with an external server located on the network
- FTP Server to upload data log files from any location on the network
- Time Manager to automatically sync the real time clock to a server or external source
- Two-way communications with popular PLC manufacturers such as Allen Bradley, GE Fanuc, and Siemens
- Available in all the pre-configured versions of the CDL Gateway™

We have 2 Product families: Gateways & HMIs

CDL Gateway Basic(LE) series



The Monico CDL Gateway™ is more than a protocol converter. It is a pre-configured solution that provides a customer **communications interface** to the Caterpillar® line of **Industrial Engines and Generator Sets** via many different protocols and data maps. The CDL Gateway™ has three host ports to choose from including two RS-232 ports, one RS-485 2-wire or 4-wire, and one Ethernet port.

After 3/31/10, all Gateways are now FLEX models that allow future addition of Input/Output modules.



- (8) Digital Inputs & (6) Digital Outputs
- (8) Thermocouple Inputs-Any type
- (6) RTD Inputs-100 ohm Platinum
- (8) Analog Voltage Inputs - 0-10V
- (8) Analog Current Inputs - 0-20 mA
- (4) Analog Outputs - Voltage or Current

Selecting the Hardware

We have 2 Product families: Gateways & HMIs

The G3 Series HMI

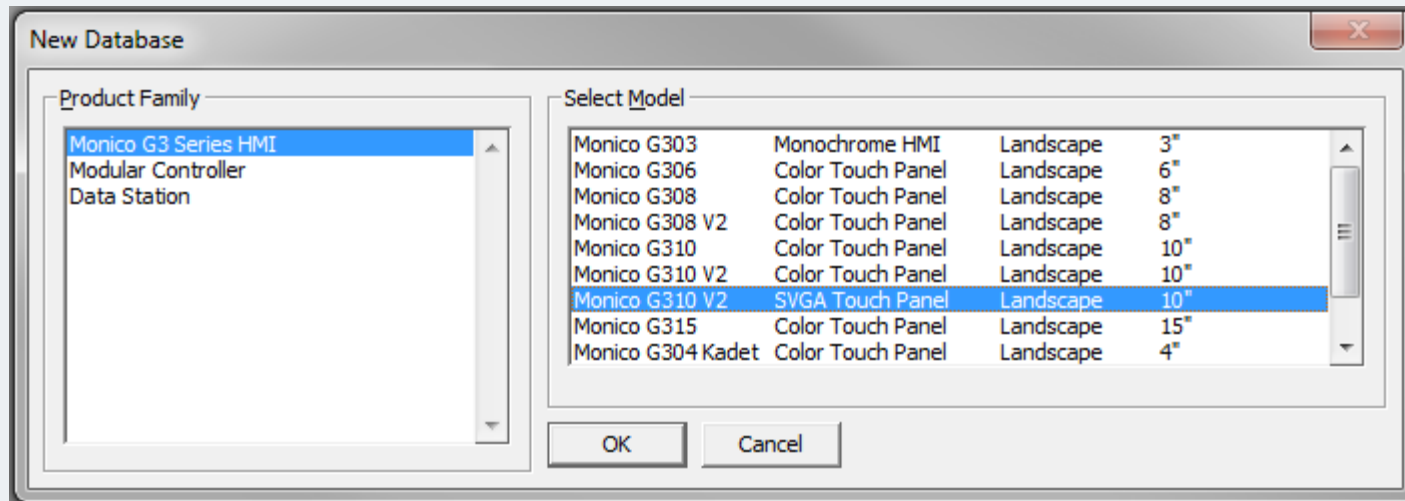

6", 8", 10", and 15" Touch Panels currently available

MonicoView™ stores all information about a Gateway's configuration in a file called a **Database**. These files have an .mvd extension although Windows Explorer will typically hide this extension.

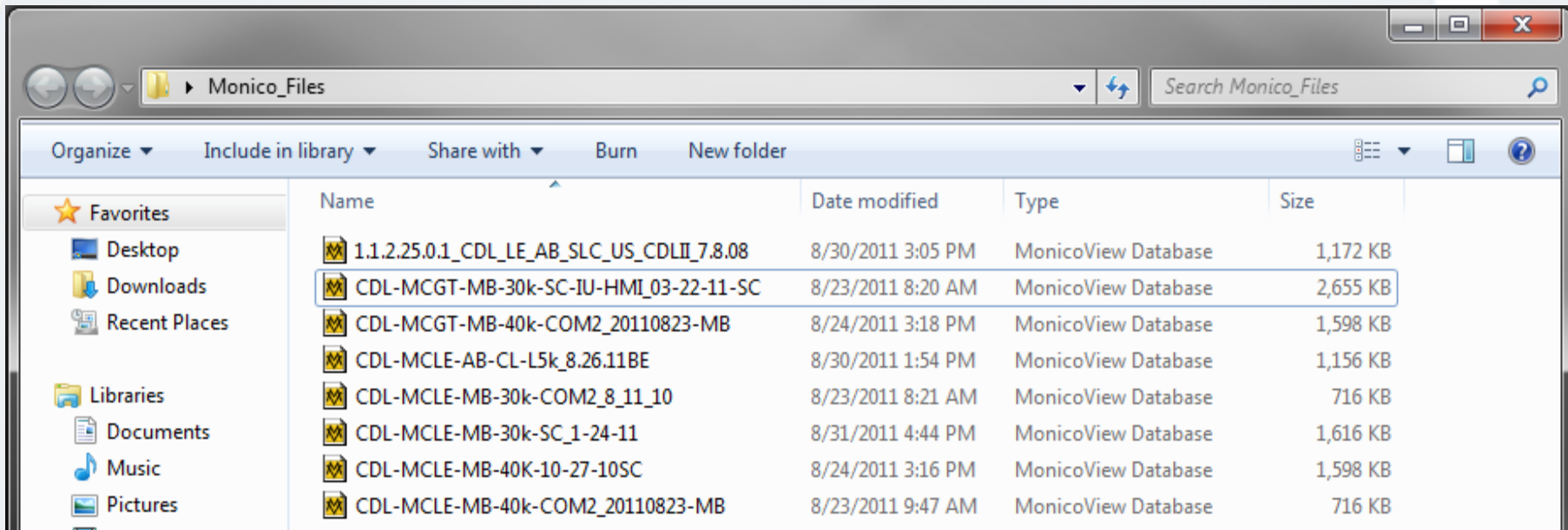

You are NOT connected to the Gateway unless you first Extract (or Download) the configuration from it!!!

MonicoView™ database files are downloaded to the Gateway by means of the “Link” menu. The download process typically takes only a few seconds, but can take somewhat longer on the first download if MonicoView™ has to update the firmware in the Gateway, or if it does not contain an older version of the current database. After this first download, however, MonicoView™ uses a process known as incremental download to ensure that only changes to the database are transferred. This means that changes can be made in seconds, thereby reducing your development cycle time and simplifying the debugging process.

Configuring the USB Link

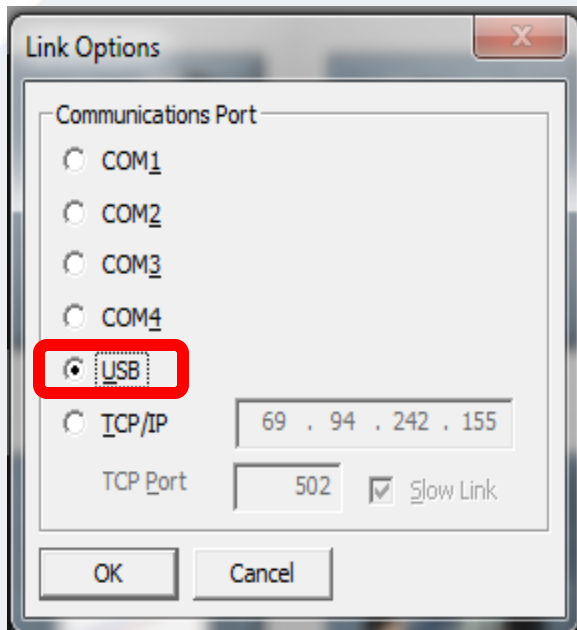

If you are using a USB cable to connect to the Gateway make sure the USB option is chosen as shown in the image on the left.

If you are using a notebook or laptop computer you need to run off of battery power prior to connecting the USB cable to the Gateway.

Configuring the Ethernet TCP/IP Link

If you are using a TCP/IP connection, you should enter the IP address of the target device in the appropriate field in the dialog box. If you leave the IP address as 0.0.0.0, MonicoView will examine the currently loaded database to see if the panel's address can be determined from the configuration information. This feature removes the need to change the IP addresses when switching between databases intended for different terminals.

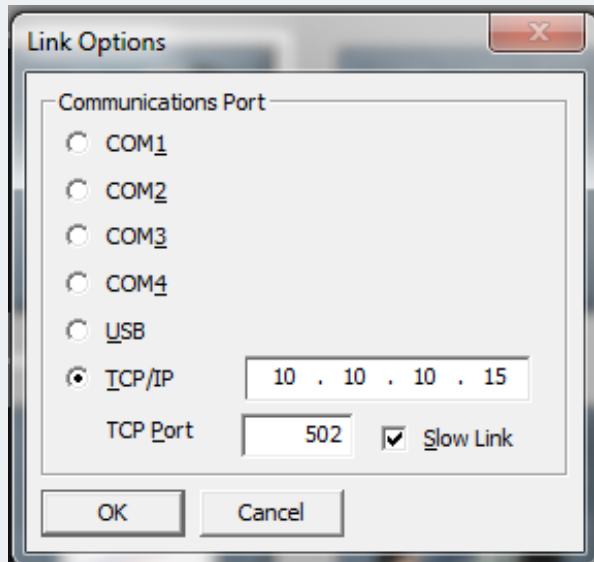

Setting the IP Address to extract from

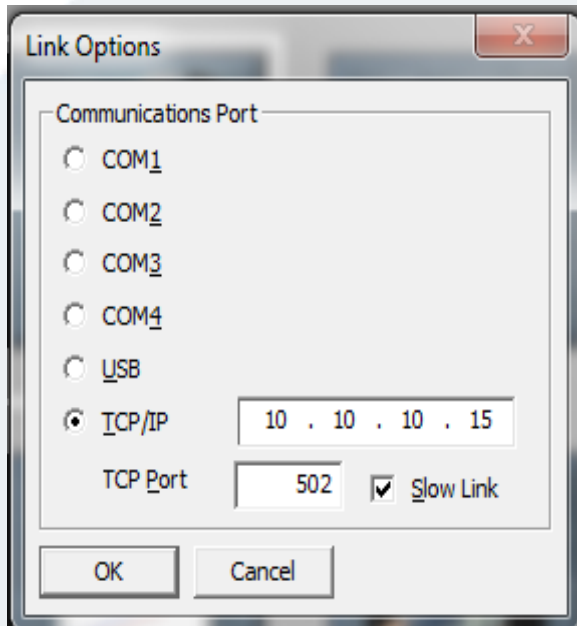

The programming link between the PC and the Gateway is made using an RS-232 serial port, a USB port, or a TCP/IP connection. While TCP/IP connections are typically made via the panel's Ethernet port, they may also be established via a dial-in link. Before downloading, you should use the "Link" then "Options" command to ensure that you have the method selected...

NOTE: This only affects where you are uploading or downloading the Database to or from. It does NOT set the Gateway to this IP address.

Sending the Database to the Gateway

Once the link is configured, the Database can be downloaded using either the “Link” “Send” or “Link” “Update” commands. “Link” “Send” will send the entire database, whether or not individual objects within the file have changed. “Link” “Update” will only send changes, and will typically take a much shorter period of time to complete.

The “Update” command is typically the only one that you will need, as MonicoView will automatically fall back to a complete “Send” if the incremental download fails for any reason. As a shortcut, note that you can access “Link” “Update” via the Lightning Bolt  symbol on the toolbar, or via the **F9 Key on the keyboard.**

Extracting Databases from the Gateway

To extract a Database from a Gateway, use the “Link” “Extract” command. This command will download the database, and then prompt you for a name under which to save the file onto your computer. The file will then be opened for editing.

If checked, the “Link” “Support Upload” command allows you to extract the configuration from the Gateway in case you lose the copy on your computer.

NOTE: If you lose your database file and you do not have “Support Upload” enabled (checked), you will not be able to reconstruct your file without starting from scratch.

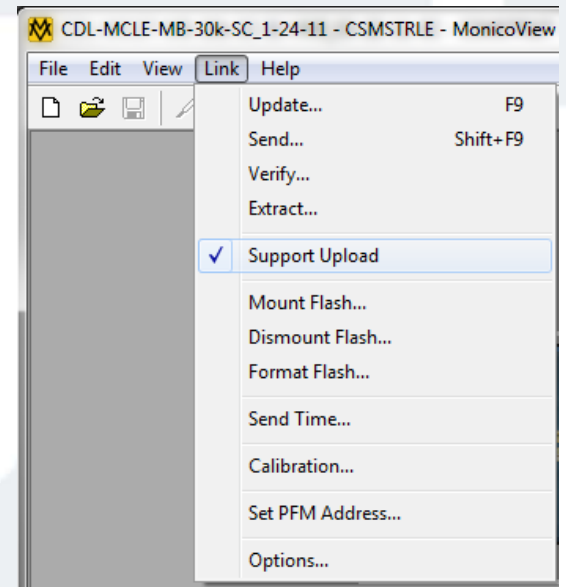

Setting the Modbus Drop Number

The Modbus Drop number is also referred to as the Node Id or Slave Id of the device. The example below shows the Drop Number as “1” for this RS-232 Comms Port.

The screenshot displays the 'Communications' configuration window. On the left, a tree view shows the device hierarchy: MC, Programming Port, RS-232 Comms Port - Modbus RTU Slave (selected), PLC1, RS-485 Comms Port, Ethernet, Protocol 1-4, and Services/OPC Server. The right pane shows the configuration for the selected 'RS-232 Comms Port - Modbus RTU Slave'. The 'Driver Selection' section shows 'Modbus RTU Slave' selected. The 'Driver Settings' section has 'Drop Number' set to '1', which is highlighted with a red box. The 'Word Ordering' section shows 'In Long Blocks' and 'In Real Blocks' both set to 'Low Then High'. The 'Port Settings' section shows 'Baud Rate' at 9600, 'Data Bits' at Eight, 'Stop Bits' at One, and 'Parity' at None. The 'Port Sharing' section shows 'Share Port' set to 'No' and 'TCP Port' set to 0. At the bottom are buttons for 'Clear Port Settings', 'Restore Driver Defaults', and 'Add Additional Device'.

Setting the Modbus Drop number

The Modbus Drop number is also referred to the Node Id or Slave Id of the device. The example below shows the Drop number as “5” for this RS-485 Comms Port.

The screenshot displays the 'Communications' configuration window. On the left, a tree view shows the hierarchy: MC > RS-485 Comms Port - Modbus RTU Slave. The right pane is divided into several sections:

- Driver Selection:** Driver: Modbus RTU Slave (with an Edit... button).
- Driver Settings:** Drop Number: 5 (highlighted with a red box).
- Word Ordering:** In Long Blocks: Low Then High; In Real Blocks: Low Then High.
- Port Settings:** Baud Rate: 9600; Data Bits: Eight; Stop Bits: One; Parity: None; Port Mode: 2-Wire RS485.
- Port Sharing:** Share Port: No; TCP Port: 0.

At the bottom, there are three buttons: Clear Port Settings, Restore Driver Defaults, and Add Additional Device.

Setting the IP Address of the Gateway

The IP Address of the Gateway is set in the Communications module and left clicking on the Ethernet protocol as shown below.

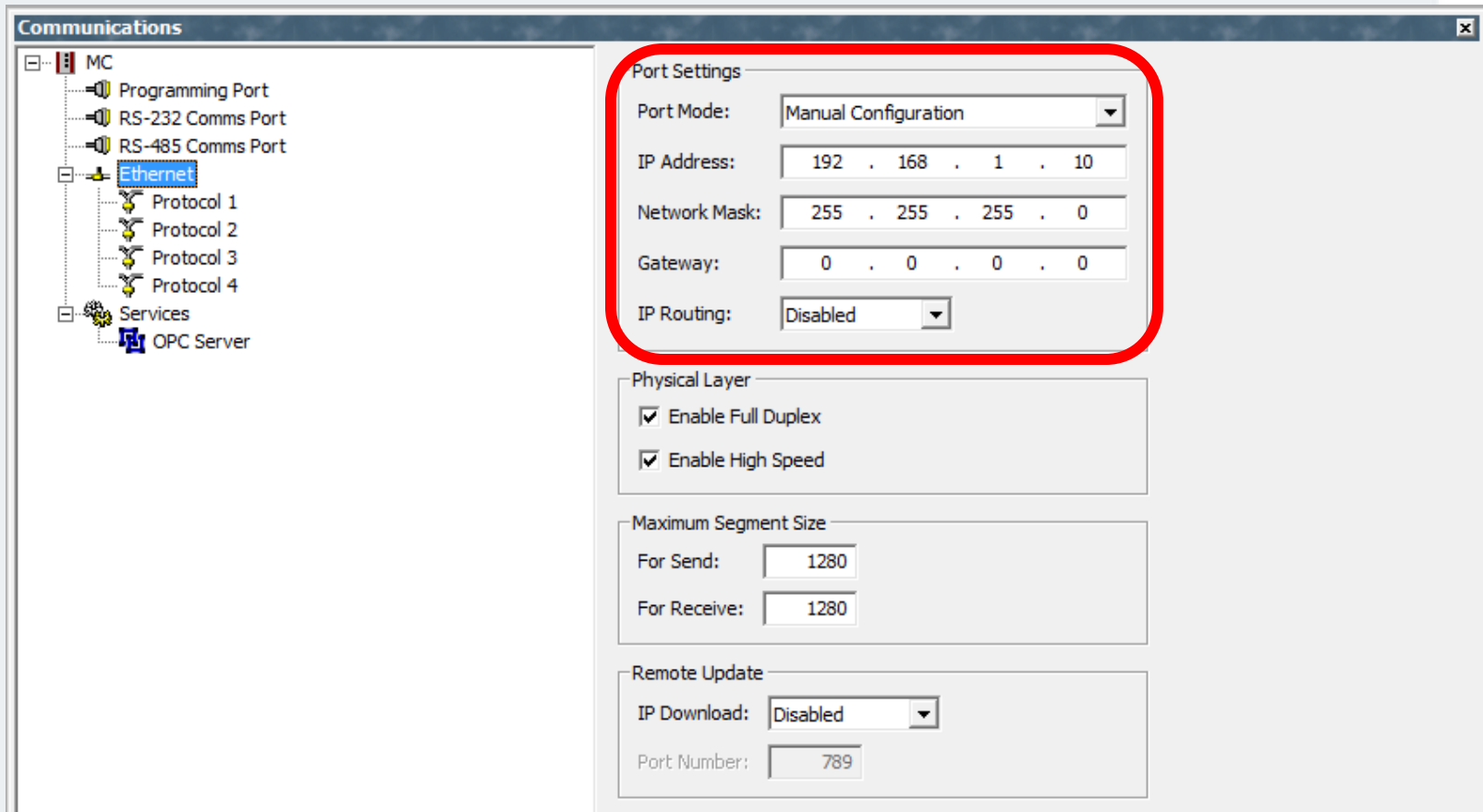

Setting the Target IP Address to your PLC

The Gateway needs to know the target IP address of your PLC in order to send data to it. The example below shows the target IP Address and Slot Number settings for an Allen-Bradley Compact Logix PLC:

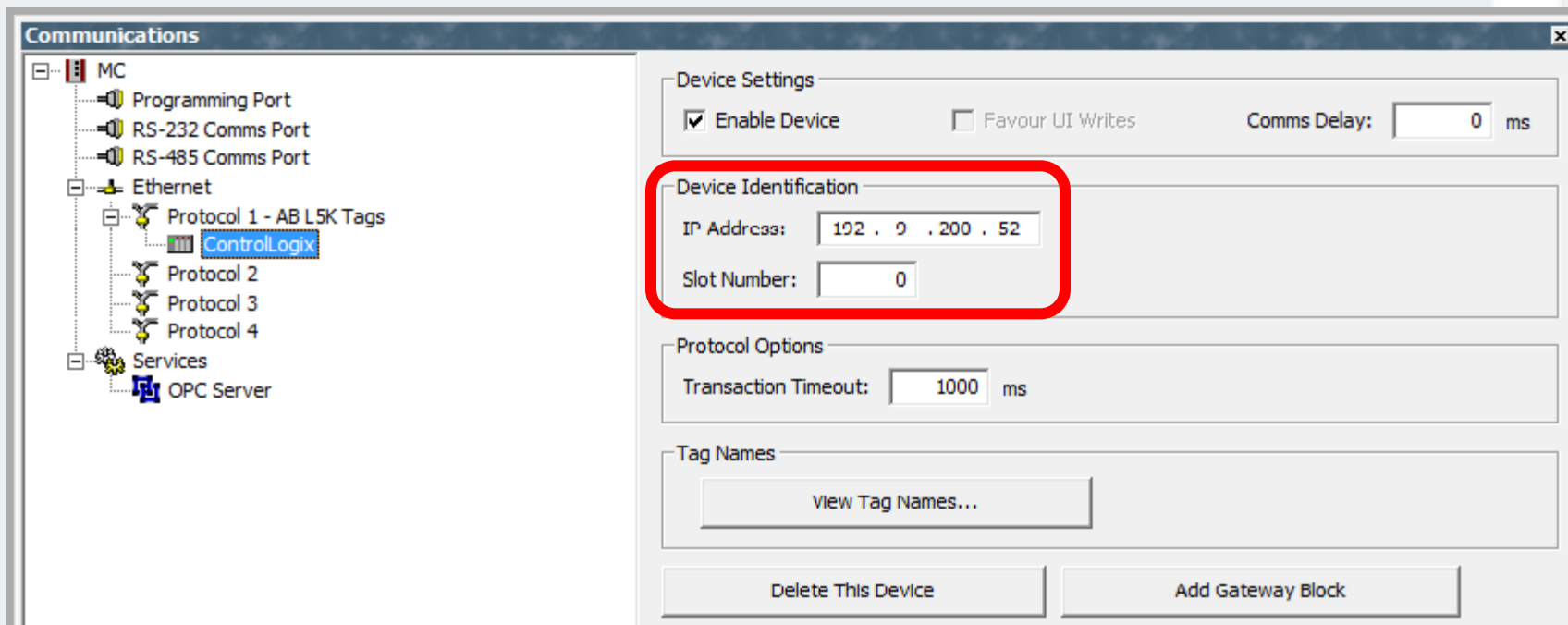

Setting the Target IP Address to your PLC

The example below shows the target IP Address setting for an Allen-Bradley SLC series PLC:

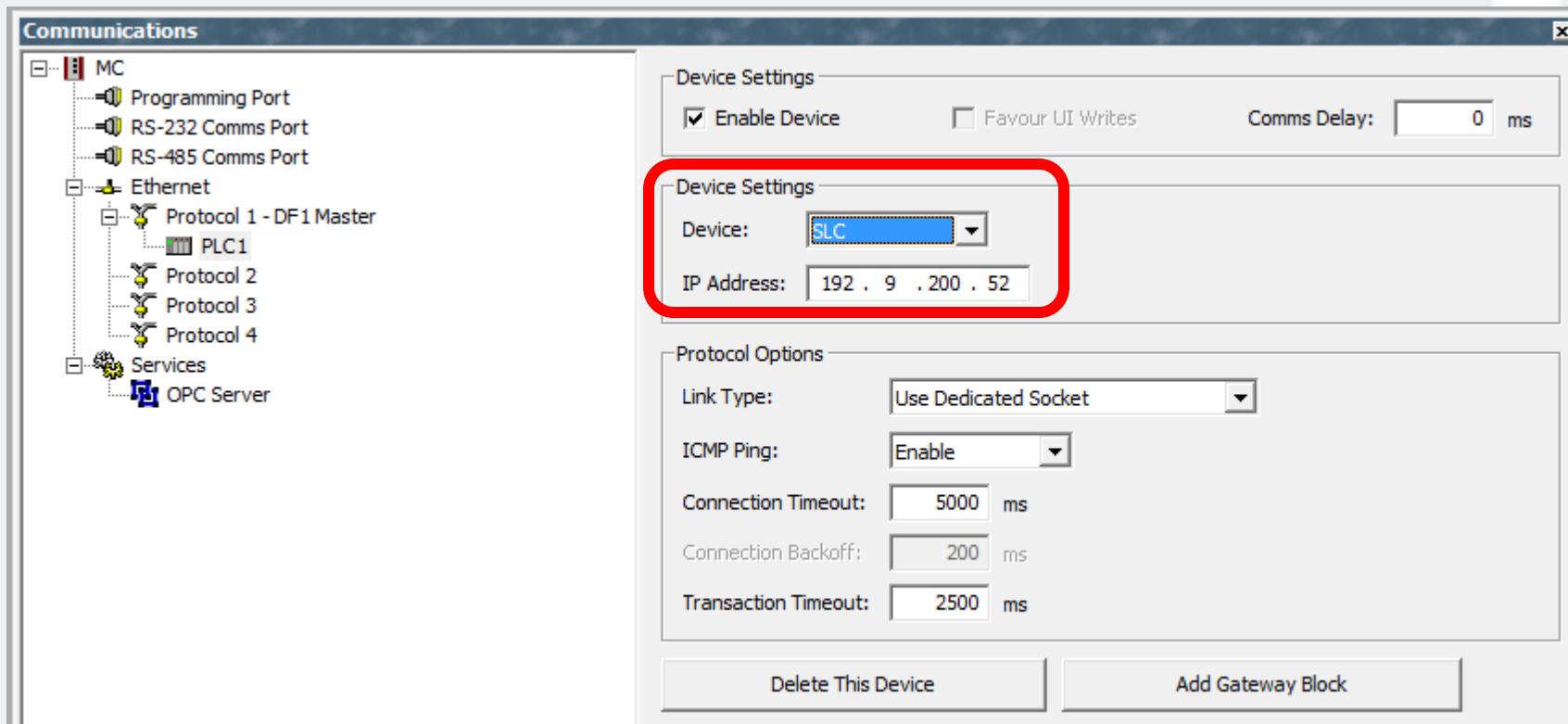

Setting the Target IP Address to your PLC

The example below shows the target IP Address setting for a GE Fanuc series PLC:

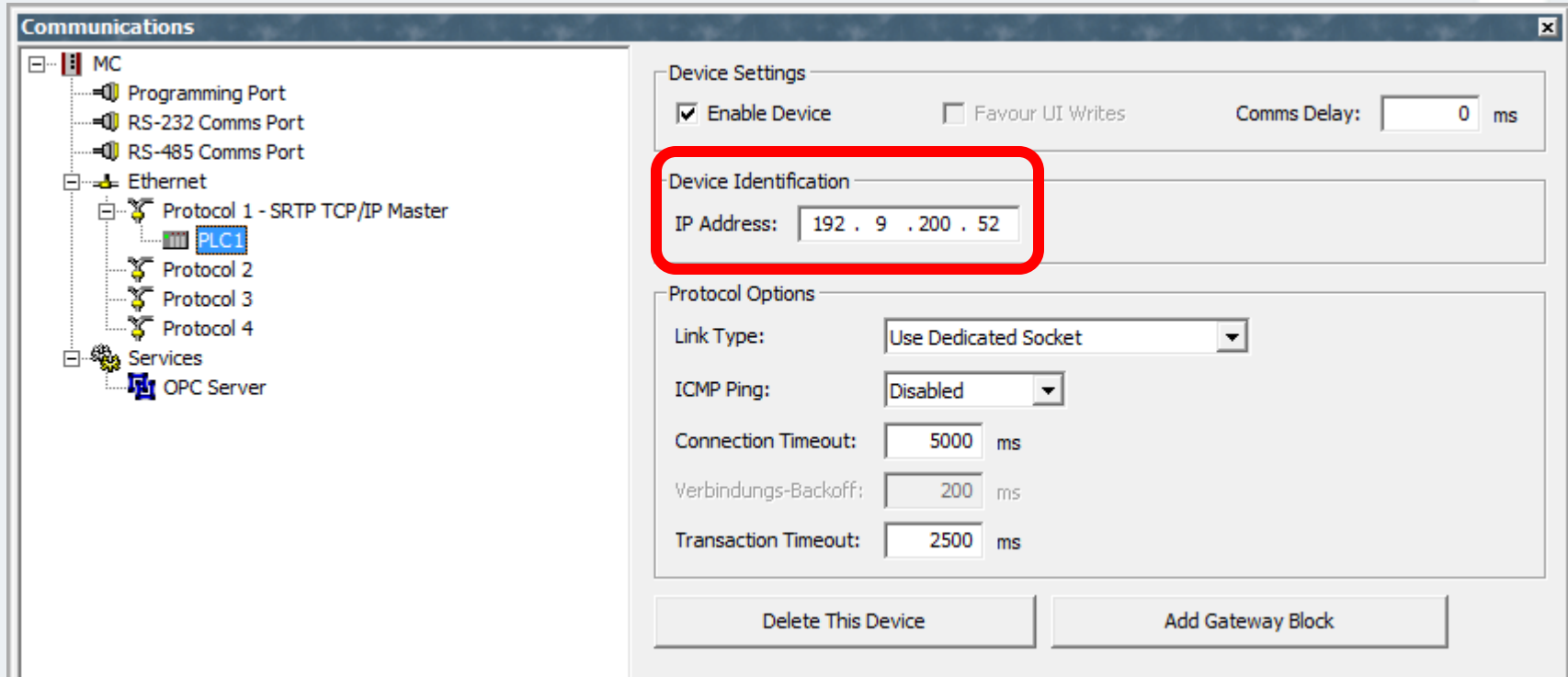

Setting the Target IP Address to your PLC

The example below shows the target IP Address and TCP Port settings for a Siemens series PLC:

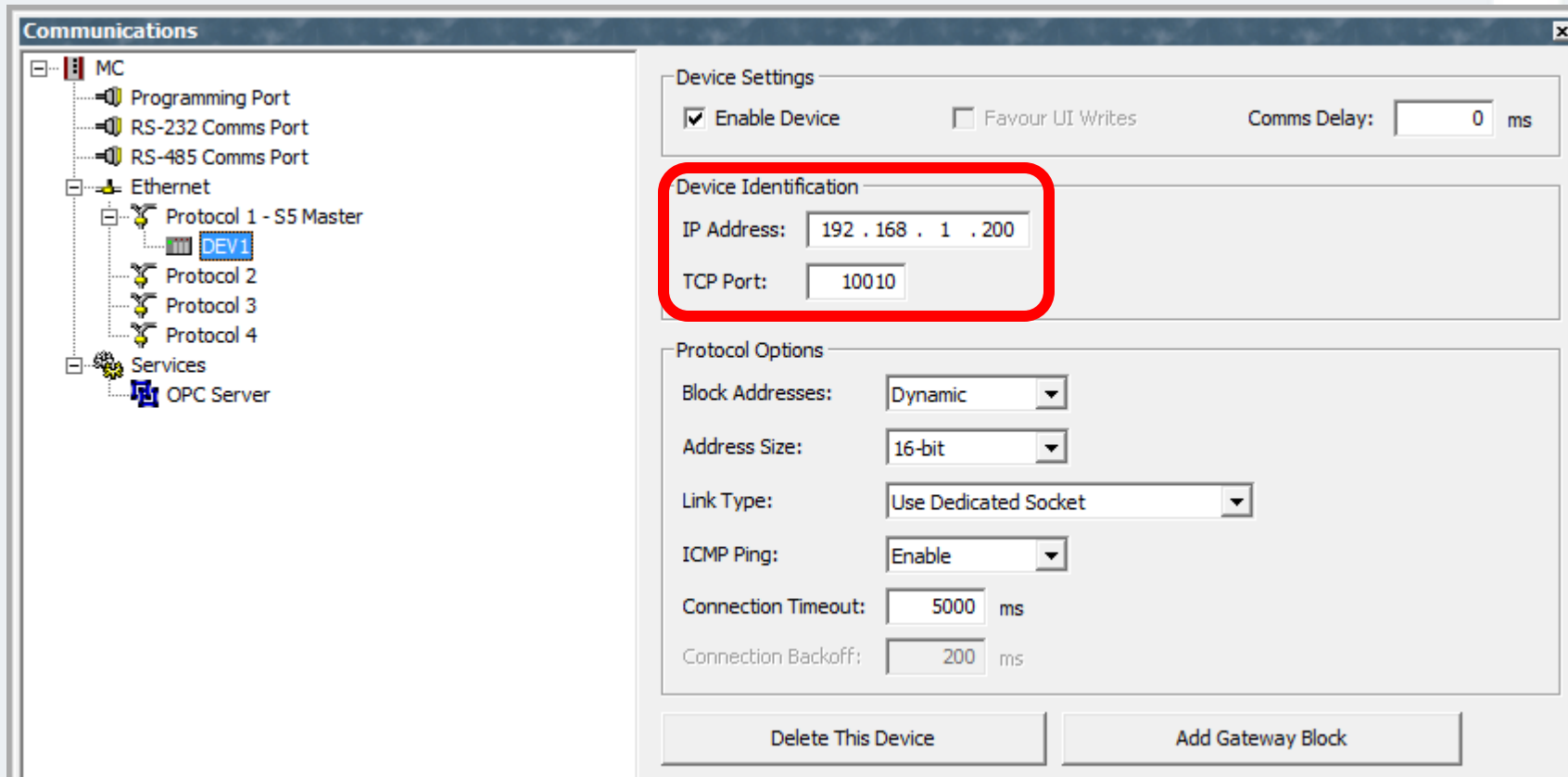

Setting the Target IP Address to your PLC

The example below shows the target IP Address and Mode settings for an Omron series PLC:

The screenshot shows the 'Communications' configuration window. On the left, a tree view shows the device hierarchy: MC > Ethernet > Protocol 1 - FINS Master > PLC1. The right pane shows the configuration for this device, with the 'Device Identification' section highlighted by a red box. The 'Device Settings' section includes 'Enable Device' (checked), 'Favour UI Writes' (unchecked), and 'Comms Delay' (0 ms). The 'Device Identification' section shows 'IP Address' set to 192.9.200.52 and 'Mode' set to CS/CJ. The 'FINS Addresses' section has fields for Destination and Source Network, Node, and Unit, all set to 0. The 'Protocol Options' section includes 'UDP Port' (9600), 'Link Type' (Use Dedicated Socket), 'ICMP Ping' (Disabled), 'Connection Timeout' (5000 ms), 'Connection Backoff' (200 ms), and 'Transaction Timeout' (2500 ms). At the bottom, there are buttons for 'Delete This Device' and 'Add Gateway Block'.

Communications

MC

- Programming Port
- RS-232 Comms Port
- RS-485 Comms Port
- Ethernet
 - Protocol 1 - FINS Master
 - PLC1
 - Protocol 2
 - Protocol 3
 - Protocol 4
 - Services
 - OPC Server

Device Settings

Enable Device Favour UI Writes Comms Delay: ms

Device Identification

IP Address: Mode:

FINS Addresses

Destination Network:	<input type="text" value="0"/>	Source Network:	<input type="text" value="0"/>
Destination Node:	<input type="text" value="0"/>	Source Node:	<input type="text" value="0"/>
Destination Unit:	<input type="text" value="0"/>	Source Unit:	<input type="text" value="0"/>

Protocol Options

UDP Port:

Link Type:

ICMP Ping:

Connection Timeout: ms

Connection Backoff: ms

Transaction Timeout: ms

Delete This Device Add Gateway Block

You **MUST** be tied into the Primary CAT Data Link (the pink & purple wires).

Roughly 15 seconds after power up, the Gateway CDL Led's will flash in unison as it looks for ECM's on the CAT Data Link. Seconds after that, the Led's will blink rapidly and alternately. This blinking indicates you are communicating on the CAT Data Link.

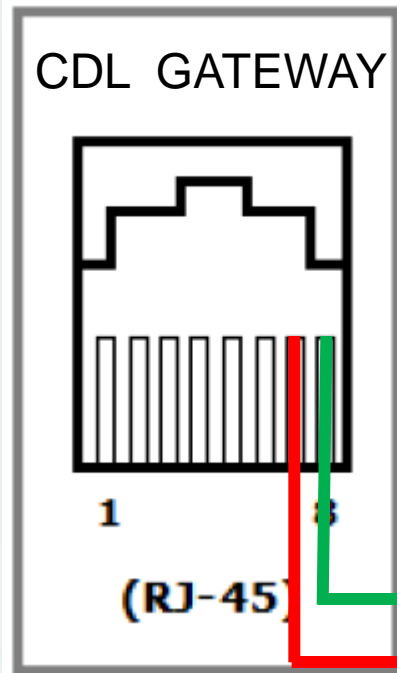

If the RED Led is solid then you have the “-” and “+” wires connected backwards. If you see NO LED activity it could be an indication that your wires are not connected or they are shorted along the path. Verify all connections and that there are no shorts and cycle the power to the Gateway before trying again.

Pin 8 Primary CDL “-”

Pin 7 Primary CDL “+”

RS485 Modbus Connections

Pins 7 & 8 of the RS485 RJ45 connector on the Gateway are used in Modbus communications as shown below.

We recommend Belden 8719 wire for RS485 applications.

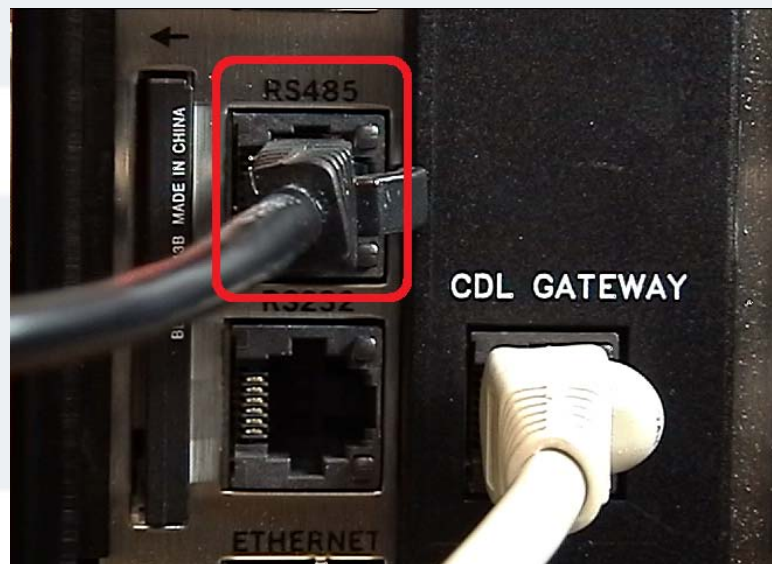
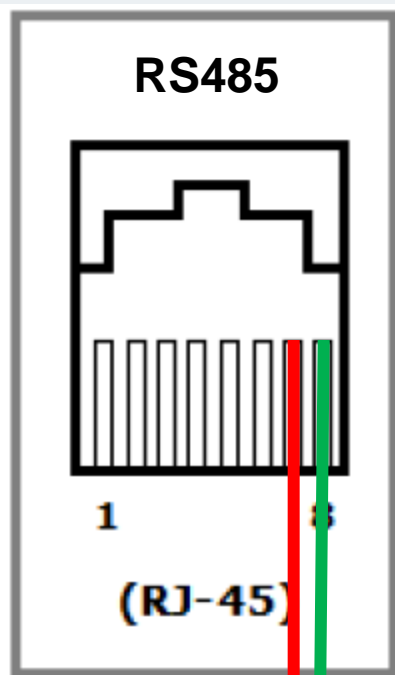

Pin 8 Modbus Data "+"

Pin 7 Modbus Data "-"

RS232 Modbus Connections

Both RS232 ports on the Gateway are available for data. Note however, that the RS232/PG port has no Led's to aid in troubleshooting.

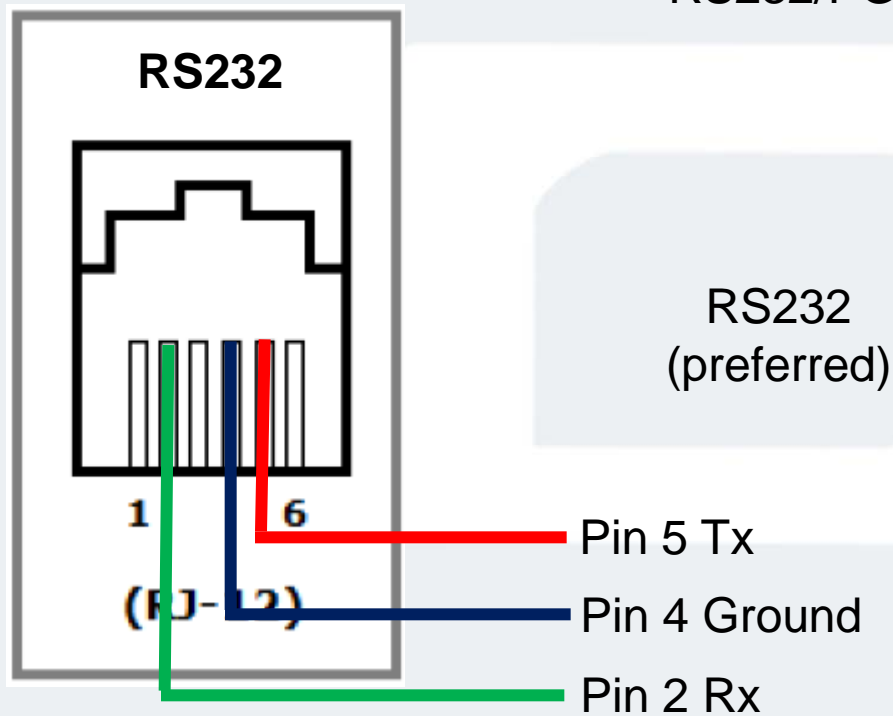

RS232/PG

RS232
(preferred)



RS232 Modbus Connections

To make a cable from the Gateway to a PC please use the diagram below. The Gateway uses a 6 pin RJ12 or RJ25 which can be found at Radio Shack or Lowe's.

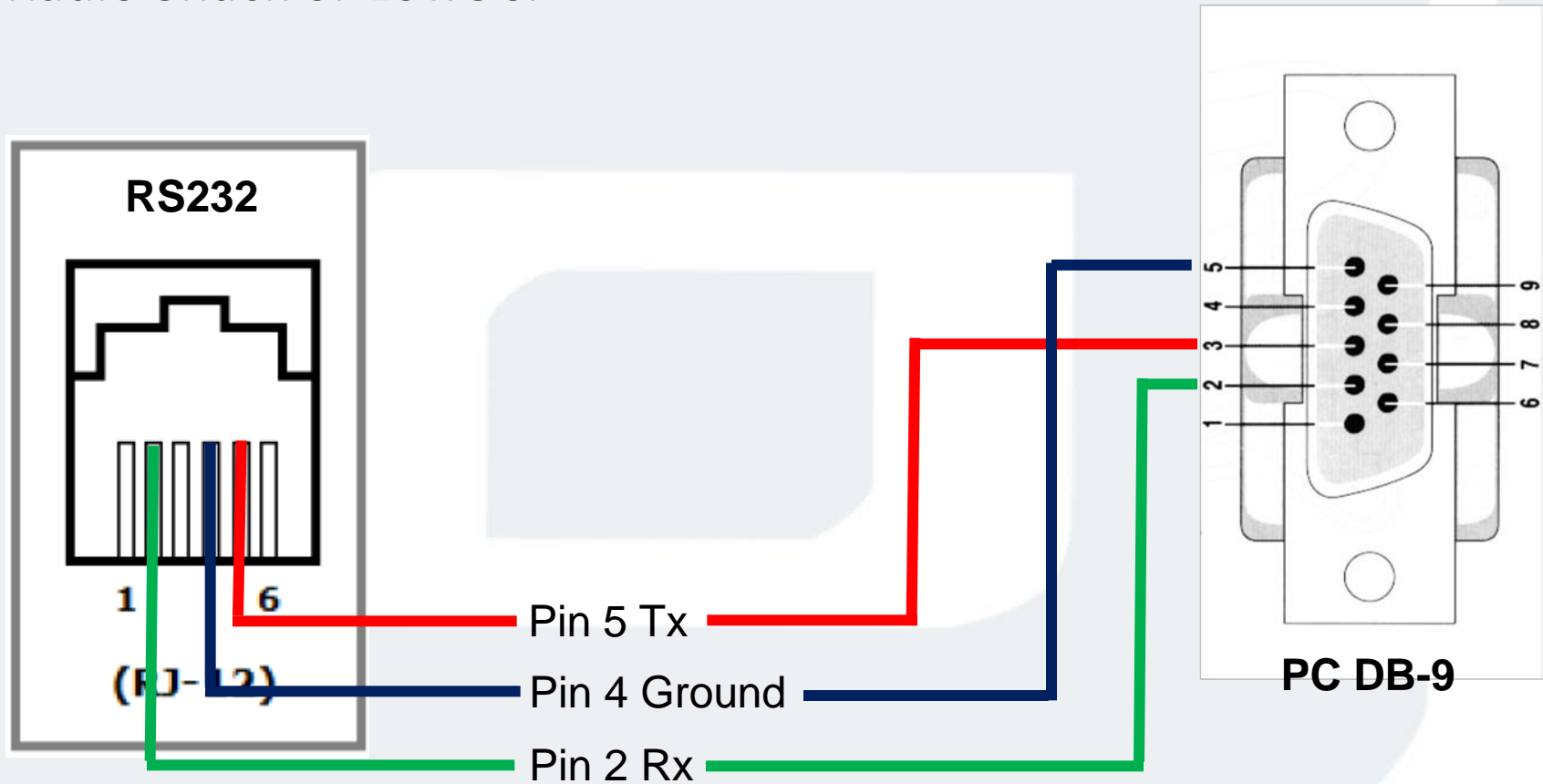

Am I Getting data?

Once everything is connected how do you know you are getting data? The first step is to go into the Communications module.

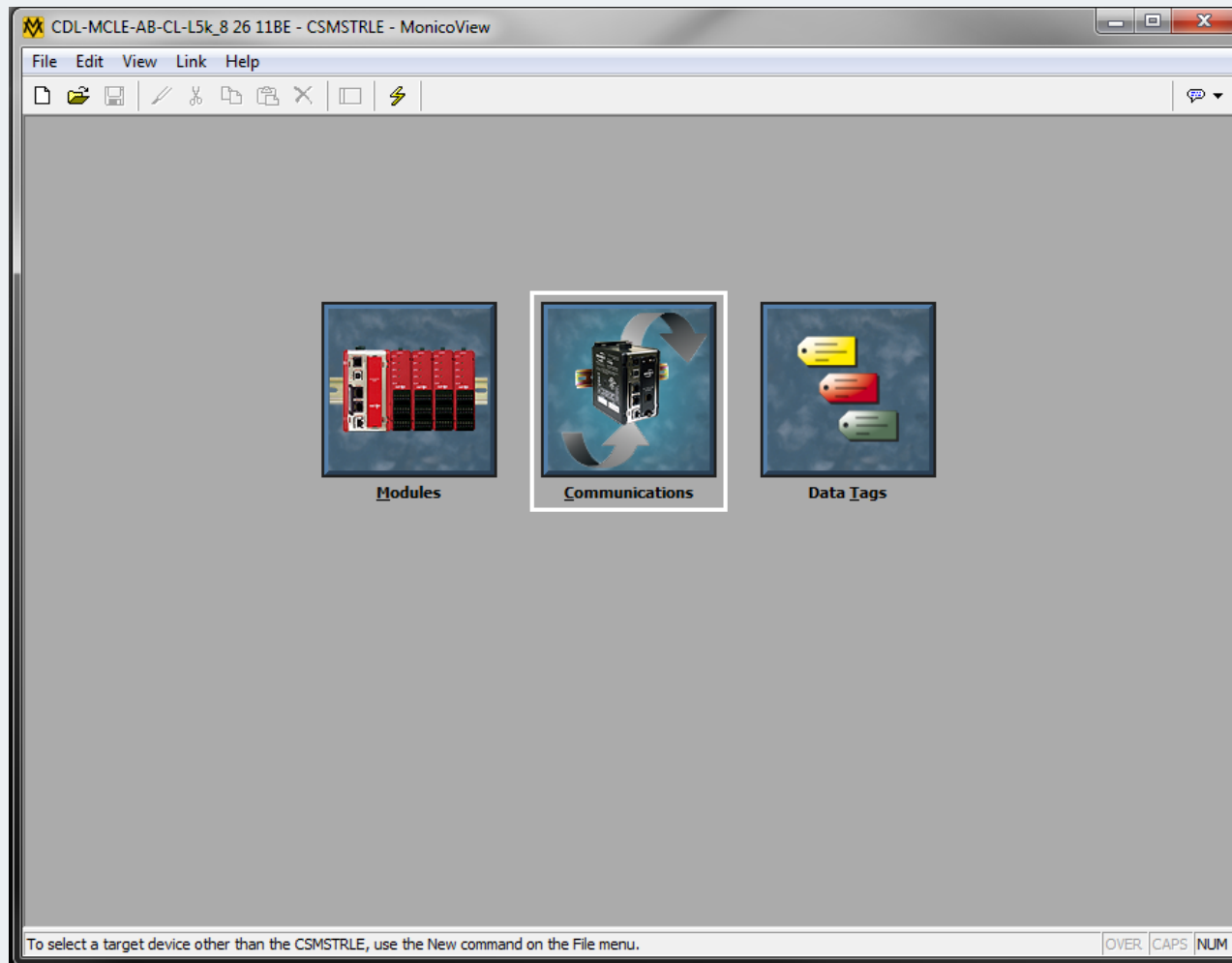

Left Click on “Block 1” under the device as shown below:

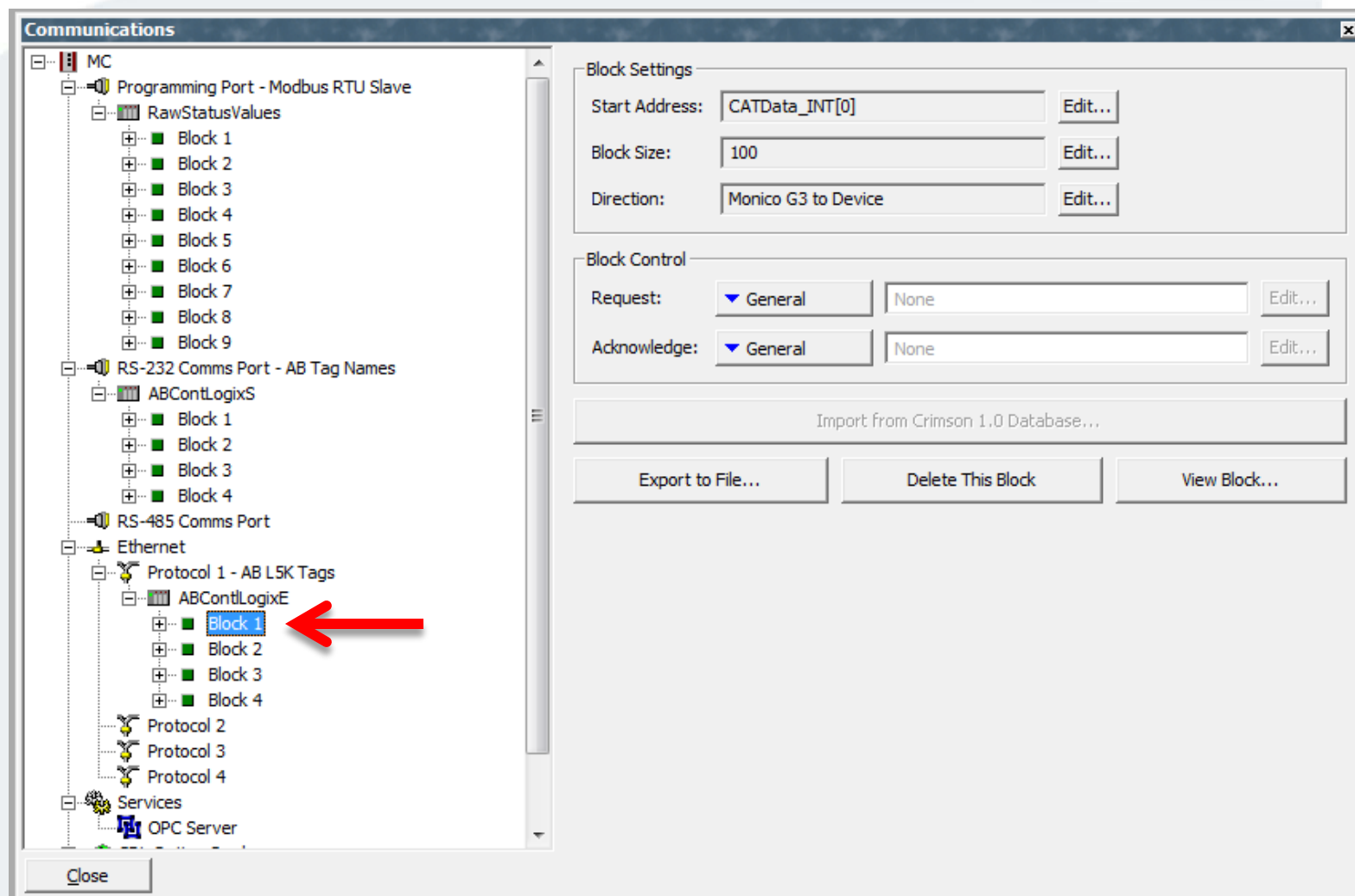

Now Right Click on “Block 1” and choose “View” as shown below

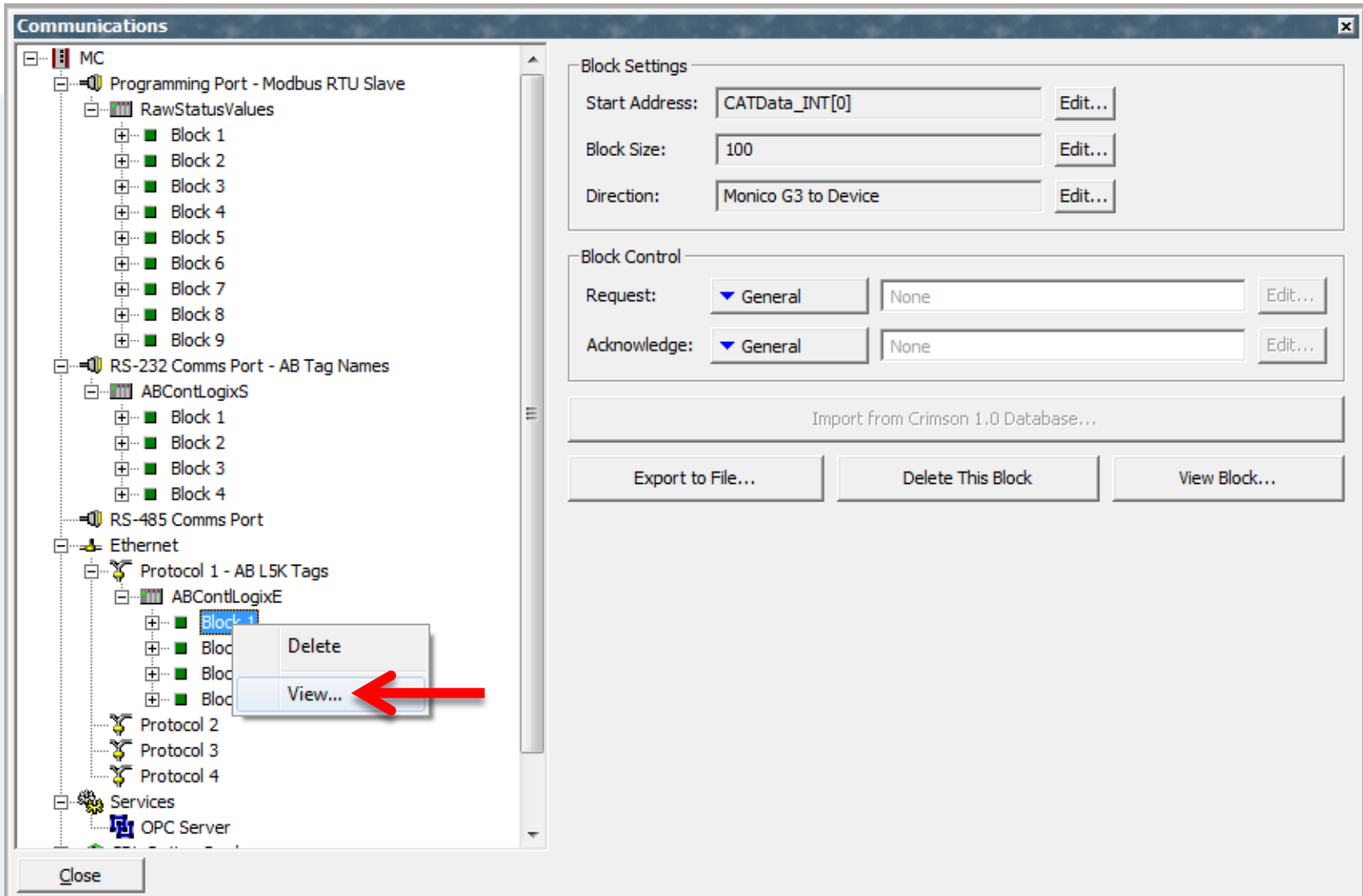

Am I getting data?

You can now scroll through the list of tags and view any data coming into the Gateway.

Communications

MC

Programming Port

RawStatusVal

Block 1

Block 2

Block 3

Block 4

Block 5

Block 6

Block 7

Block 8

Block 9

RS-232 Comms Po

ABContLogixS

Block 1

Block 2

Block 3

Block 4

RS-485 Comms Po

Ethernet

Protocol 1 - A

ABContLe

Block

Block

Block

Block

Protocol 2

Protocol 3

Protocol 4

Services

OPC Server

View Data via USB

Data

Name	Mapping	Decimal	Hex	Real
CATData_INT[0]	CDL1_NO_SPEED_...	0	0x0000	
CATData_INT[1]	CDL2_SPEED_TIMI...	0	0x0000	
CATData_INT[2]	CDL3_DETONATION	0	0x0000	
CATData_INT[3]	CDL4_NUMBER_D...	0	0x0000	
CATData_INT[4]	CDL5_ENGINE_TYPE	0	0x0000	
CATData_INT[5]	CDL6_O2_SENSOR...	0	0x0000	
CATData_INT[6]	CDL7_REMOTE_FA...	0	0x0000	
CATData_INT[7]	CDL8_IGN_TIMING...	0	0x0000	
CATData_INT[8]	CDL9_INT_MAN_T...	32	0x0000	
CATData_INT[9]	CDL10_COOLDOW...	0	0x0000	
CATData_INT[10]	CDL11_COOL_MO...	0	0x0000	
CATData_INT[11]	CDL12_ENG_PREL...	0	0x0000	
CATData_INT[12]	CDL13_REM_STAR...	0	0x0000	
CATData_INT[13]	CDL14_ENG_COOL...	0	0x0000	
CATData_INT[14]	CDL15_ENG_CON...	0	0x0000	
CATData_INT[15]	CDL16_SD_NOT_R...	0	0x0000	

Status

Reading Data - Update Count is 351

Close

A value indicates data is being received.

A "0" indicates no data is being received or is not available.

Next Steps

- For more resources please visit our website:
<http://www.monicoinc.com/support.php>
- For more video tutorials please visit us on YouTube
at: <http://www.youtube.com/user/MonicoInc>

Thank-You!