

## MODELS CSMSTRSX AND CSMSTRGT – ENHANCED MODULAR CONTROLLER SERIES MASTER



Powered by  
**red ipn**



FOR USE IN HAZARDOUS LOCATIONS:  
 Class I, Division 2, Groups A, B, C, and D

- PROVIDES ENHANCED FEATURES FOR DATA ACQUISITION OR MULTI-ZONE PID CONTROL APPLICATIONS
- WEBSERVER PROVIDES WORLDWIDE ACCESS TO DATA LOGS AND VIRTUAL HMI
- VIRTUAL HMI OFFERS BUILT-IN PC-BASED SCADA FUNCTIONALITY
- PERFORMS HIERARCHICAL CONTROL OF OTHER MODULES IN THE MODULAR CONTROLLER SERIES
- STORES MODULE CONFIGURATION INFORMATION, AND AUTOMATICALLY REPROGRAMS REPLACED MODULES
- EXTENSIVE BUILT-IN DRIVER LIST ALLOWS EASY DATA MAPPING TO PLCs, PCs, AND SCADA SYSTEMS
- INDEPENDENT SERIAL PORTS PROVIDE VIRTUALLY UNLIMITED INTEGRATION METHODS
- 10 BASE-T/100 BASE-TX ETHERNET CONNECTION PROVIDES NETWORKING CAPABILITY
- SUPPORTS UP TO 16 MODULAR CONTROLLER SERIES MODULES
- COMPACTFLASH® SLOT ALLOWS PROCESS DATA TO BE LOGGED DIRECTLY TO CSV FILES



### GENERAL DESCRIPTION

The Model CSMSTR is a communications and control platform designed for use with Modular Controller Series slave modules. The CSMSTR uses a proprietary high speed serial protocol to communicate, via backplane connection, with up to 16 slave modules. Through the same connection, the Master also provides power to the modules.

When powered up, the CSMSTR automatically identifies and addresses connected slave modules. By storing the configuration information of all of the modules, the CSMSTR is able to automatically configure modules if they are replaced.

The Master provides high-speed RS232/422/485 communication ports and an Ethernet port for connection to PCs, PLCs, and SCADA systems. An extensive list of master and slave protocol drivers are available to allow the CSMSTR to share and exchange variable data with external devices. The 10 Base-T/100 Base-TX Ethernet port can also be used to connect and share data with other devices at high speeds. The virtual HMI feature allows you to create and control an HMI from any networked PC. An onboard CompactFlash slot provides storage for the Master's built-in data logger.

The design of the Modular Controller Series high density packaging and DIN rail mounting saves time and panel space. The controller snaps easily onto standard top hat (T) profile DIN rail.

### SOFTWARE

The CSMSTR is programmed with Monico View™ software for Windows® 2000 or later platforms. The software is an easy to use, graphical interface which provides a means of communication configuration, as well as commissioning and calibration of new systems.

### CONTENTS OF PACKAGE

- CS Master
- Termination Plug
- Terminal Block for connecting power
- Rubber End Cap

### SAFETY SUMMARY

All safety related regulations, local codes and instructions that appear in the manual or on equipment must be observed to ensure personal safety and to prevent damage to either the instrument or equipment connected to it. If equipment is used in a manner not specified by the manufacturer, the protection provided by the equipment may be impaired.

Do not use the controller to directly command motors, valves, or other actuators not equipped with safeguards. To do so can be potentially harmful to persons or equipment in the event of a fault to the controller. An independent and redundant temperature limit indicator with alarm outputs is strongly recommended.

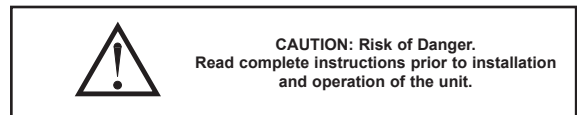
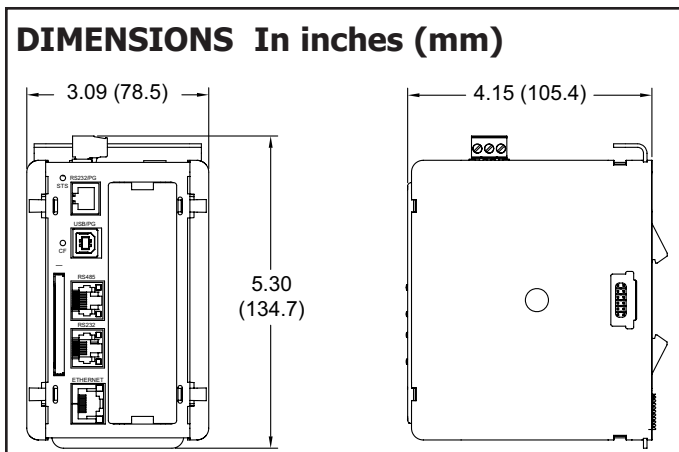

- ⚠ WARNING - EXPLOSION HAZARD - SUBSTITUTION OF COMPONENTS MAY IMPAIR SUITABILITY FOR CLASS I, DIVISION 2
- ⚠ THIS EQUIPMENT IS SUITABLE FOR USE IN CLASS I, DIVISION 2, GROUPS A, B, C, D, OR NON-HAZARDOUS LOCATIONS ONLY

CompactFlash is a registered trademark of CompactFlash Association.

# SPECIFICATIONS

- POWER:** 24 VDC  $\pm$  10%  
400 mA min. (1 module)  
3.5 Amps max. (16 modules + Expansion Card)  
Must use NEC Class 2 or Limited Power Source (LPS) rated power supply.
- COMMUNICATIONS:**  
**USB/PG Port:** Adheres to USB specification 1.1. Device only using Type B connection.



WARNING - DO NOT CONNECT OR DISCONNECT CABLES WHILE POWER IS APPLIED UNLESS AREA IS KNOWN TO BE NON-HAZARDOUS. USB PORT IS FOR SYSTEM SET-UP AND DIAGNOSTICS AND IS NOT INTENDED FOR PERMANENT CONNECTION.

- Serial Ports:** Format and Baud Rates for each port are individually software programmable up to 115,200 baud.
- RS232/PG Port:** RS232 port via RJ12
- COMMS Ports:** RS422/485 port via RJ45, and RS232 port via RJ12
- DH485 TXEN:** Transmit enable; open collector,  $V_{OH} = 15$  VDC,  
 $V_{OL} = 0.5$  V @ 25 mA max.
- Ethernet Port:** 10 BASE-T / 100 BASE-TX  
RJ45 jack is wired as a NIC (Network Interface Card).
- LEDs:**  
STS – Status LED indicates condition of master.  
TX/RX – Transmit/Receive LEDs show serial activity.  
Ethernet – Link and activity LEDs.  
CF – CompactFlash LED indicates card status and read/write activity
  - MEMORY:**  
On-board User Memory: 4 Mbytes of non-volatile Flash memory.  
On-board SDRAM:  
  CSMSTRSX: 2 Mbytes  
  CSMSTRGT: 8 Mbytes  
Memory Card: CompactFlash Type II slot for Type I and Type II cards.
  - REAL-TIME CLOCK:** Typical accuracy is less than one minute per month drift. Monico View's SNTP facility allows synchronization with external servers.  
Battery: Lithium Coin Cell. Typical lifetime of 10 years at 25 °C.  
  A "Battery Low" system variable is available so that the programmer can choose specific action(s) to occur when the battery voltage drops below its nominal voltage.  
  This unit is NOT field serviceable. All work must be done by a qualified technician.
  - ENVIRONMENTAL CONDITIONS:**  
Operating Temperature Range: 0 to 50 °C  
Storage Temperature Range: -30 to +70 °C  
Operating and Storage Humidity: 80% max relative humidity, non-condensing, from 0 to 50 °C  
Vibration According to IEC 68-2-6: Operational 10 to 150 Hz, 0.075 mm amplitude in X, Y, Z direction for 1.5 hours, 1 g.  
Shock According to IEC 68-2-27: Operational 25 g's, 11 msec in 3 directions.  
Altitude: Up to 2000 meters

- CONSTRUCTION:** Case body is black high impact plastic and stainless steel. For indoor use only. Installation Category II, Pollution Degree 2.
- POWER CONNECTION:** Removable wire clamp screw terminal block.  
Wire Gage Capacity: 24 AWG to 12 AWG  
Torque: 4.45 to 5.34 in/lb (0.5 to 0.6 N-m)
- MOUNTING:** Snaps onto standard DIN style top hat (T) profile mounting rails according to EN50022 -35 x 7.5 and -35 x 15.
- CERTIFICATIONS AND COMPLIANCES:**

**SAFETY**  
UL Listed, File #E302106, UL508, CSA 22.2 No. 14-M05; File #E179259, UL61010-1, CAN/CSA-C22.2 No. 61010-1; and File #E317425, ANSI/ISA 12.12.01-2007, CSA 22.2 No. 213-M1987  
LISTED by Und. Lab. Inc. to U.S. and Canadian safety standards  
IECEE CB Scheme Test Report #E179259-A5-CB-1  
Issued by Underwriters Laboratories Inc.  
IEC 61010-1, EN 61010-1: Safety requirements for electrical equipment for measurement, control, and laboratory use, Part 1.

**ELECTROMAGNETIC COMPATIBILITY**  
Emissions and Immunity to EN 61326: 2006: Electrical Equipment for Measurement, Control and Laboratory use.

<b>Immunity to Industrial Locations:</b>		
Electrostatic discharge	EN 61000-4-2	Criterion B 4 kV contact discharge 8 kV air discharge
Electromagnetic RF fields	EN 61000-4-3	Criterion B <sup>3</sup> 10 V/m
Fast transients (burst)	EN 61000-4-4	Criterion B power 2 kV I/O signal 1 kV
Surge	EN 61000-4-5	I/O signal connected to power 2 kV Criterion B power 1kV L-L, 2 kV L-G signal 1kV
RF conducted interference	EN 61000-4-6	Criterion A 3 V/rms

**Emissions:**  
Emissions EN 55011 Class A

- Notes:*
- Criterion A: Normal operation within specified limits.*
  - Criterion B: Temporary loss of performance from which the unit self-recovers.*
  - The modules with analog input and/or output signals may have their signals deviate during disturbance but self-recover when disturbance is removed.*

- WEIGHT:** 15.1 oz (456.4 g)



WARNING - EXPLOSION HAZARD - DO NOT DISCONNECT EQUIPMENT UNLESS POWER HAS BEEN SWITCHED OFF OR AREA IS KNOWN TO BE NON-HAZARDOUS.

# HARDWARE INSTALLATION

DIN rail should be mounted horizontally so that the unit's ventilation holes are vertical in relation to cabinet orientation. A minimum clearance of 1 inch (25.4 mm) should be maintained above and below the unit in order to ensure proper thermal regulation.

The unit shall be installed inside a UL Listed Industrial Control Panel or similar type of enclosure. A minimum 3.2 mm distance shall be maintained between the hazardous live parts of the equipment and accessible parts of the fire/electrical enclosure.

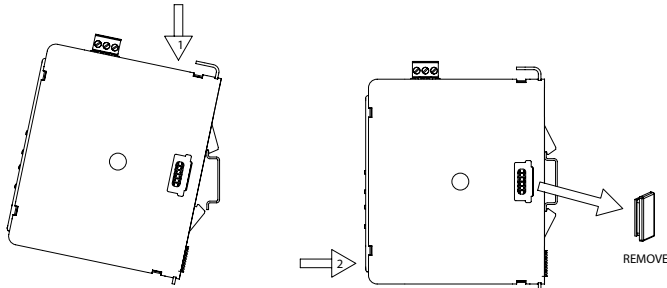

**Figure 1 - Attach CSMSTR Master To DIN Rail and Remove Rubber End Cap**

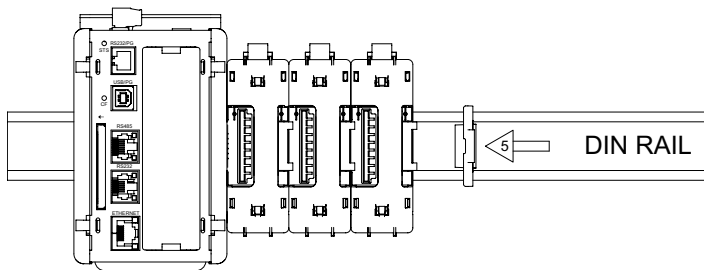

**Figure 3 - Attach Termination Plug\***  
\* Supplied with CSMSTR Master Module.

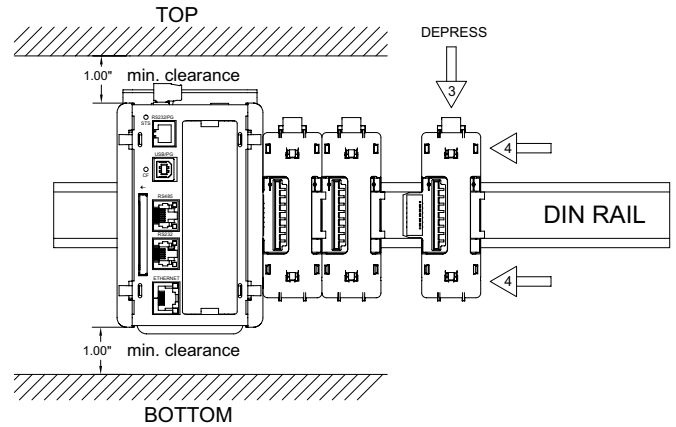

**Figure 2 - Attach Slave Bases To DIN Rail**

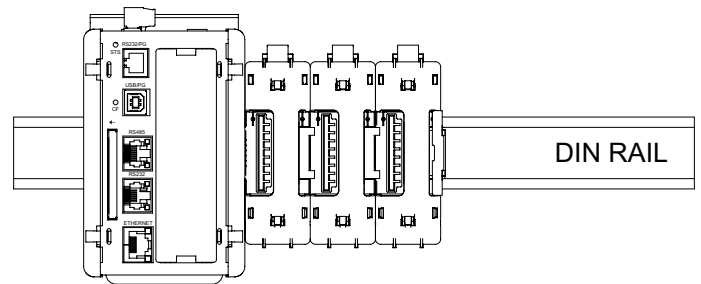

**Figure 4 - Installation Complete**

## PROTOCOL CONVERSION

Mount the Master as shown under Hardware Installation Figure 1 above. Install the rubber end cap. The end cap protects the pins from damage. Configure the Master for zero modules.

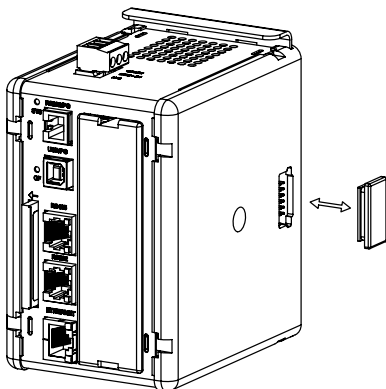

### NOTE

For reliable operation of this and other Monico™ products, one of the following brands of CompactFlash card must be used ...

SimpleTech      SMART® Modular  
SanDisk®        Silicon Systems

*Not all of the above manufacturers offer CompactFlash cards recognized to UL standards, which may be required for your application.*

## COMPACTFLASH® CARD

CompactFlash socket is a Type II socket that can accept either Type I or II cards. Use cards with a minimum of 4 Mbytes and a maximum of 2 Gbytes with the Master's CompactFlash socket. Cards are available at most computer and office supply retailers. CompactFlash can be used for configuration transfers, data logging, and trending.

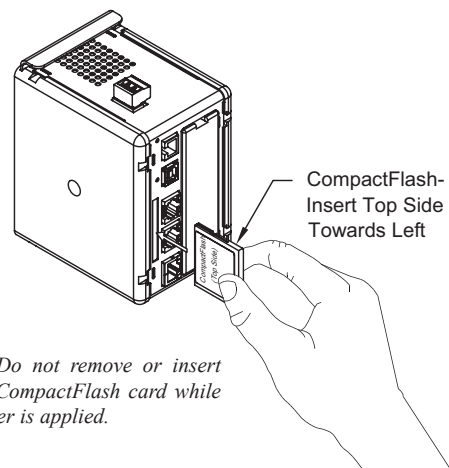

*Note: Do not remove or insert the CompactFlash card while power is applied.*

Information stored on a CompactFlash card can be read by a card reader attached to a PC. This information is stored in IBM (Windows®) PC compatible FAT16 file format.

## POWER SUPPLY REQUIREMENTS

It is very important that the power supply is mounted correctly if the unit is to operate reliably. Please take care to observe the following points:

- The power supply must be mounted close to the unit, with usually not more than 6 feet (1.8 m) of cable between the supply and the master. Ideally, the shortest length possible should be used.
- The wire used to connect the master's power supply should be at least 22-gage wire. If a longer cable run is used, a heavier gage wire should be used. The routing of the cable should be kept away from large contactors, inverters, and other devices which may generate significant electrical noise.
- A power supply with an NEC Class 2 or Limited Power Source (LPS) and SELV rating is to be used. This type of power supply provides isolation to accessible circuits from hazardous voltage levels generated by a mains power supply due to single faults. SELV is an acronym for "safety extra-low voltage." Safety extra-low voltage circuits shall exhibit voltages safe to touch both under normal operating conditions and after a single fault, such as a breakdown of a layer of basic insulation or after the failure of a single component has occurred.

## EMC INSTALLATION GUIDELINES

Although Monico Products are designed with a high degree of immunity to Electromagnetic Interference (EMI), proper installation and wiring methods must be followed to ensure compatibility in each application. The type of the electrical noise, source or coupling method into a unit may be different for various installations. Cable length, routing, and shield termination are very important and can mean the difference between a successful or troublesome installation. Listed are some EMI guidelines for a successful installation in an industrial environment.

1. To reduce the chance of noise spikes entering the unit via the power lines, connections should be made to a clean source. Connecting to circuits that also power loads such as contactors, relays, motors, solenoids etc. should be avoided.
2. The unit should be mounted in a metal enclosure, which is properly connected to protective earth.
3. Use shielded (screened) cables for all Signal and Control inputs. The shield (screen) pigtail connection should be made as short as possible. The connection point for the shield depends somewhat upon the application. Listed below are the recommended methods of connecting the shield, in order of their effectiveness.
  - a. Connect the shield to earth ground (protective earth) at one end where the unit is mounted.
  - b. Connect the shield to earth ground at both ends of the cable, usually when the noise source frequency is over 1 MHz.
  - c. Connect the shield to common of the master and leave the other end of the shield unconnected and insulated from earth ground.
4. Never run Signal or Control cables in the same conduit or raceway with AC power lines, conductors feeding motors, solenoids, SCR controls, and heaters, etc. The cables should be run through metal conduit that is properly grounded. This is especially useful in applications where cable runs are long and portable two-way radios are used in close proximity or if the installation

is near a commercial radio transmitter. Also, Signal or Control cables within an enclosure should be routed as far away as possible from contactors, control relays, transformers, and other noisy components.

5. Long cable runs are more susceptible to EMI pickup than short cable runs. Therefore, keep cable runs as short as possible.
6. In extremely high EMI environments, the use of external EMI suppression devices is effective. The following EMI suppression devices (or equivalent) are recommended:

Ferrite Suppression Cores for signal and control cables:

- Fair-Rite part number 0443167251
- TDK part number ZCAT3035-1330A
- Steward part number 28B2029-0A0

Line Filters for input power cables:

- Schaffner part number FN610-1/07
- Schaffner part number FN670-1.8/07
- Corcom part number 1 VR3

## WIRING

### POWER CONNECTION

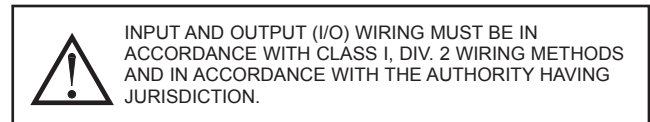
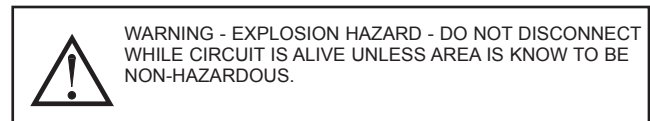
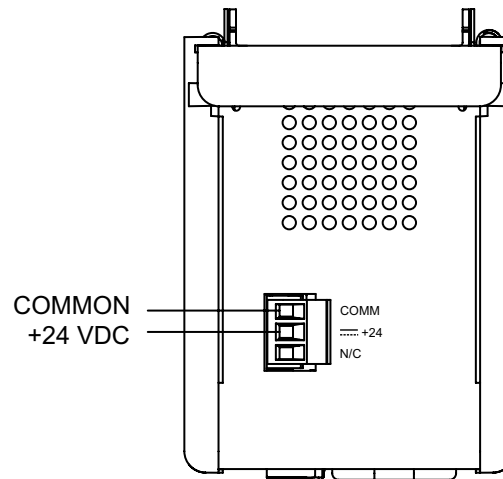

## PROGRAMMING PORTS

### RS232/PG

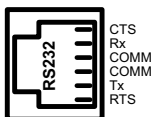

### USB/PG



### ETHERNET

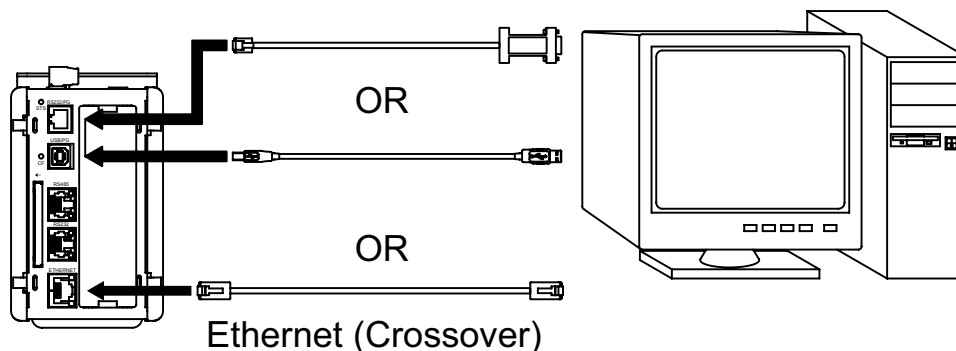

# COMMUNICATION PORTS

## RS232/PG

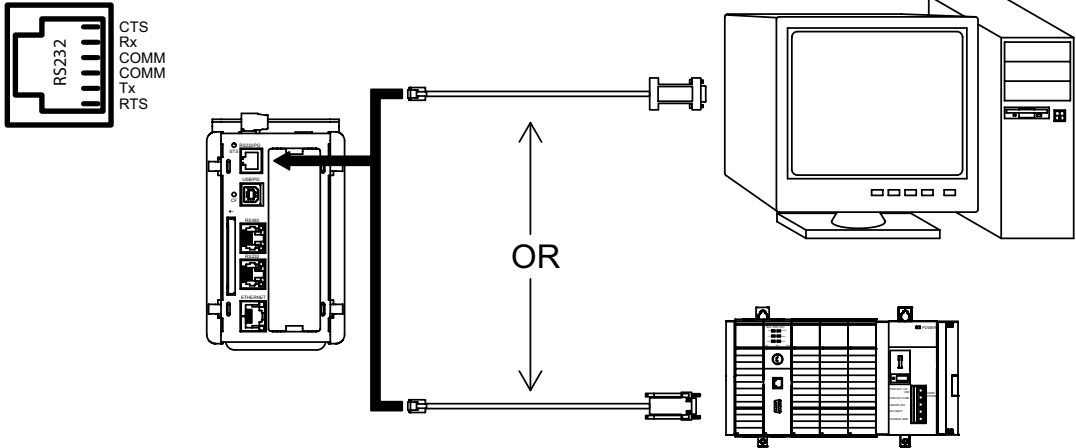

## RS232

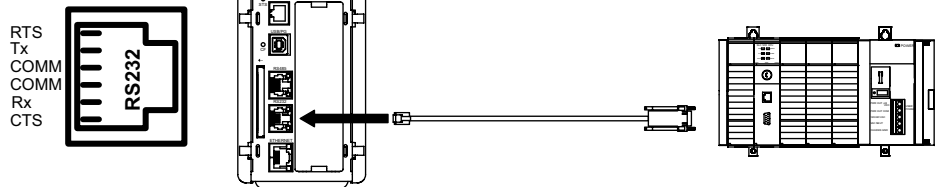

\* Use appropriate communications cable. See Ordering Information for descriptions of the available cables.

## RS485

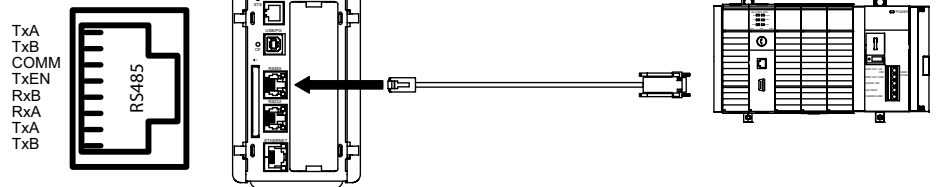

**WARNING:** Do **NOT** use a standard DH-485 cable to connect this port to Allen Bradley equipment.

## PORT 3 - ETHERNET CONNECTION

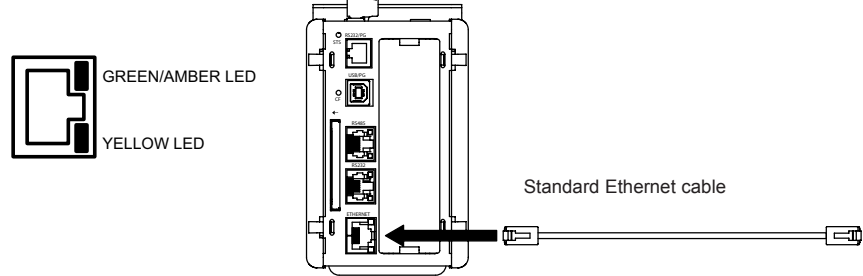

# MASTER PORT PIN OUTS

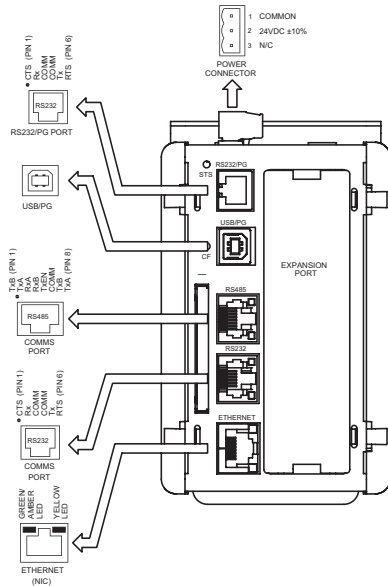

## TROUBLESHOOTING

If for any reason you have trouble operating, connecting, or simply have questions concerning your new Master, contact Monico's technical support. For contact information, refer to the back page of this bulletin for phone and fax numbers.

EMAIL: [support@monicoinc.com](mailto:support@monicoinc.com)  
 Web Site: <http://www.monicoinc.com>

# COMMUNICATING WITH THE MASTER

## CONFIGURING A MASTER

The Master is configured using Monico View software. Monico View is available as a free download from Monico's website, or it can be ordered on CD. Updates to Monico View for new features and drivers are posted on the website as they become available. By configuring the Master using the latest version of Monico View, you are assured that your unit has the most up to date feature set. Monico View software can configure the Master through the RS232/PG port, USB/PG port, Ethernet or CompactFlash. The USB/PG port is connected using a standard USB cable with a Type B connector.

The driver needed to use the USB port will be installed with Monico View. The RS232/PG port uses a programming cable made by Monico to connect to the DB9 COM port of your computer. If making your own cable, refer to the "Master Port Pin Outs" for wiring information.

The CompactFlash can be used to program a Master by placing a configuration file and firmware on the CompactFlash card. The card is then inserted into the target Master and powered. Refer to the Monico View literature for more information on the proper names and locations of the files.

## CABLES AND DRIVERS

Monico has a wide range of cables and drivers for use with many different communication types. A list of these drivers and cables along with pin outs is available from Monico's website. New cables and drivers are added on a regular basis. If making your own cable, refer to the "Master Port Pin Outs" for wiring information.

## USB, DATA TRANSFERS FROM THE COMPACTFLASH CARD



**WARNING - DO NOT CONNECT OR DISCONNECT CABLES WHILE POWER IS APPLIED UNLESS AREA IS KNOWN TO BE NON-HAZARDOUS. USB PORT IS FOR SYSTEM SET-UP AND DIAGNOSTICS AND IS NOT INTENDED FOR PERMANENT CONNECTION.**

In order to transfer data from the CompactFlash card via the USB port, a driver must be installed on your computer. This driver is installed with Monico View and is located in the folder C:\Program Files\Monico\Monico View\Device\ after Monico View is installed. This may have already been accomplished if your Master was configured using the USB port.

Once the driver is installed, connect the Master to your PC with a USB cable, and follow "Mounting the CompactFlash" instructions in the Monico View user manual.

Note that using the USB port for frequent data transfers is not recommended. For frequent data transfers it is recommended that the Ethernet connection be used. Through the Ethernet connection a web page can be set up to view logged data. Refer to the Monico View manual for details.

*Note: The USB port is for system set-up and diagnostics and is not intended for permanent connection.*

## ETHERNET COMMUNICATIONS

Ethernet communications can be established at either 10 BASE-T or 100 BASE-TX. The Master's RJ45 jack is wired as a NIC (Network Interface Card). For example, when wiring to a hub or switch use a straight-through cable, but when connecting to another NIC use a crossover cable.

## RS422/485 PORT

The Master has one RS422/485 port. This port can be configured to act as either RS422 or RS485.

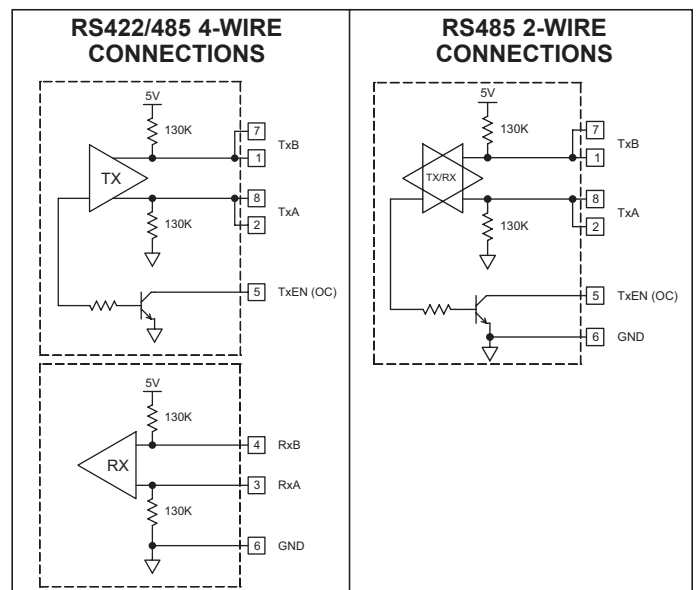

## RS232 PORTS

The Master has two RS232 ports. There is the RS232/PG port and the COMMS port. Although only one of these ports can be used for programming, both ports can be used for communications with a PLC. The RS232/PG port can be used for either master or slave protocols.

## DH485 COMMUNICATIONS

The Master's RS422/485 COMMS port can also be used for Allen Bradley DH485 communications.

**WARNING:** DO NOT use a standard DH485 cable to connect this port to Allen Bradley equipment. A cable and wiring diagram are available from Monico.

## LEDS

### STS – STATUS LED

The green Status LED provides information regarding the state of the Master, as well as the rest of the system. This includes indication of the various stages of the start-up routine (power-up), and any errors that may occur.

#### Startup Routine

	INDICATION
Rapidly Flashing	Master is currently running the boot loader and/or being flash upgraded by Monico View.
Steady	Master is operating properly.

#### Error States

LED	INDICATION
1 blink, pause, repeat	One or more slave modules are missing from the system. Master and installed modules will perform normally in this state.
2 blinks, pause, repeat	Missing configuration, or configuration being updated by Monico View.
3 blinks, pause, repeat	Quantity of module bases does not match configuration file. Master will not communicate with the modules until the error is corrected.
4 blinks, pause, repeat	Termination plug not installed, or one or more bases are malfunctioning. Master will not communicate with the modules until the plug is reinstalled, and power is cycled.

## CF LED

LED	INDICATION
Off	No CompactFlash Card is present.
Steady	Valid CompactFlash card is present.
Flashing Rapidly	CompactFlash card is being checked.
Flickering	Unit is writing to the CompactFlash, either because it is storing data, or because the PC connected via the USB port has locked the drive. <sup>1</sup>
Flashing Slowly	Incorrectly formatted CompactFlash card present.

1. Do not turn off power to the unit while this light is flickering. The unit writes data in two minute intervals. Later Microsoft operating systems will not lock the drive unless they need to write data; Windows 98 may lock the drive any time it is mounted, thereby interfering with logging. Refer to "Mounting the CompactFlash" in the Monico View User Manual.

## USER COMMUNICATION PORTS - TX/RX LEDS

LED	INDICATION
GREEN	Transmitting
RED	Receiving

Note: LEDs are not available on the Programming Port: RS232/PG.

## ETHERNET LEDS

LED	INDICATION
YELLOW (Solid)	Link Established
YELLOW (Flashing)	Network Activity
GREEN	10 BASE-T Communications
AMBER	100 BASE-TX Communications

## ORDERING INFORMATION

TYPE	MODEL NO.	DESCRIPTION	PART NUMBER
Master Module	CSMSTR	Modular Controller Master with multiple protocol converter, data logger, web server with Virtual HMI up to QVGA (320 x 240) size and expansion slot.	OEMDA025
		Modular Controller Master with multiple protocol converter, data logger, web server with Virtual HMI up to VGA (640 x 480) size and expansion slot with increased SDRAM.	OEMDA026

#### **LIMITED WARRANTY**

The Company warrants the products it manufactures against defects in materials and workmanship for a period limited to two years from the date of shipment, provided the products have been stored, handled, installed, and used under proper conditions. The Company's liability under this limited warranty shall extend only to the repair or replacement of a defective product, at The Company's option. The Company disclaims all liability for any affirmation, promise or representation with respect to the products.

The customer agrees to hold Red Lion Controls harmless from, defend, and indemnify RLC against damages, claims, and expenses arising out of subsequent sales of RLC products or products containing components manufactured by RLC and based upon personal injuries, deaths, property damage, lost profits, and other matters which Buyer, its employees, or sub-contractors are or may be to any extent liable, including without limitation penalties imposed by the Consumer Product Safety Act (P.L. 92-573) and liability imposed upon any person pursuant to the Magnuson-Moss Warranty Act (P.L. 93-637), as now in effect or as amended hereafter.

No warranties expressed or implied are created with respect to The Company's products except those expressly contained herein. The Customer acknowledges the disclaimers and limitations contained herein and relies on no other warranties or affirmations.

Red Lion Controls  
20 Willow Springs Circle  
York PA 17406  
Tel +1 (717) 767-6511  
Fax +1 (717) 764-0839

Monico Monitoring, Inc.  
3403 Chapel Square Dr.  
Spring TX 77388  
Tel +1 (281) 350-8751  
Fax +1 (281) 754-4633