

MODEL CSDIO - MODULAR CONTROLLER SERIES DIGITAL MODULE

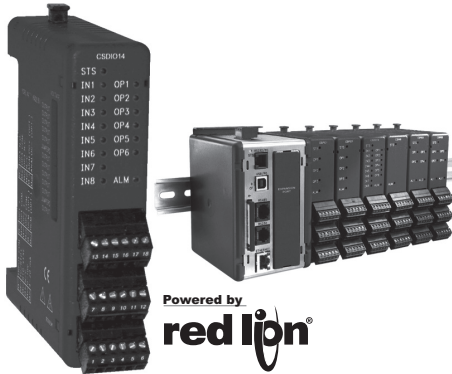

- ADDS REMOTE I/O CAPABILITY TO THE MODULAR CONTROLLER SERIES
- EIGHT INPUT, SIX OUTPUT DIGITAL MODULE
- INPUTS ISOLATED FROM OUTPUTS
- INPUTS INDEPENDENTLY SWITCH SELECTABLE FOR SINK OR SOURCE SIGNALS
- INPUTS INDEPENDENTLY CONFIGURABLE FOR HIGH OR LOW ACTIVE STATE
- INPUTS INDEPENDENTLY SWITCH SELECTABLE FOR HIGH OR LOW FREQUENCY SIGNALS
- RELAY OR NFET OUTPUT MODELS AVAILABLE



FOR USE IN HAZARDOUS LOCATIONS:
 Class I, Division 2, Groups A, B, C, and D



For Model No. OEMDA022 (CSDIO14U) Only

GENERAL DESCRIPTION

The Model CSDIO series modules are digital I/O modules designed for use with the Modular Controller Series. The CSDIO14 offers eight inputs and six outputs that can be used to monitor contact or sensor inputs and actuate relays, solenoids, PLC inputs, etc.

The inputs accept standard DC inputs or contact closures, and are configured for Sink/Source signals via external switches. Additionally, each input has a switch selectable input filter that can be used to prevent contact bounce. Each input may also be software configured as a high-active or low-active input.

The modules are available with relay or NFET outputs that are capable of switching up to one amp each (NFET DC only). For applications requiring large loads to be controlled, several DIN rail mount relays are available.

The CSDIO modules connect and communicate via a backplane connection to the CSMSTR Modular Controller Series Master. The CSMSTR, equipped with serial ports as well as an Ethernet port, allows the system to share data with PCs, PLCs, and SCADA systems. The Master supports any combination of up to 16 CS Series modules.

Internal power management circuits allow the modules to be replaced while power is applied, which reduces downtime in the event of a relay failure. All configuration information is stored locally within each module, as well as in the Master, so replacement modules do not need to be configured. The Modular

Controller Series' high density packaging and DIN rail mounting saves time and panel space. The backplane connection provides power and communication to the module and snaps easily onto standard top hat (T) profile DIN rail.

CONFIGURATION

The Modular Controller Series is configured with Windows® compatible Monico View™ software. The software is an easy to use, graphical interface that provides a means of communication configuration, as well as commissioning and calibration of new systems.

SAFETY SUMMARY

All safety related regulations, local codes and instructions that appear in the manual or on equipment must be observed to ensure personal safety and to prevent damage to either the instrument or equipment connected to it. If equipment is used in a manner not specified by the manufacturer, the protection provided by the equipment may be impaired.

Do not use the module to directly command motors, valves, or other actuators not equipped with safeguards. To do so can be potentially harmful to persons or equipment in the event of a fault to the module.

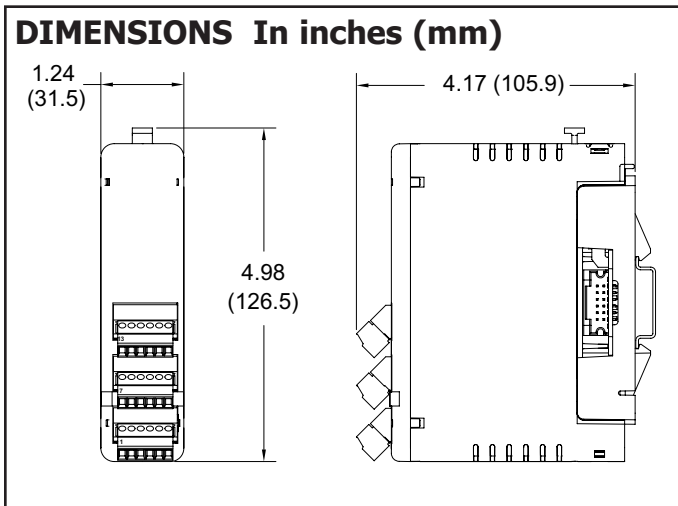





CAUTION: Risk of Danger.
Read complete instructions prior to installation and operation of the unit.



CAUTION: Risk of electric shock.

-  WARNING - EXPLOSION HAZARD - SUBSTITUTION OF COMPONENTS MAY IMPAIR SUITABILITY FOR CLASS I, DIVISION 2
-  THIS EQUIPMENT IS SUITABLE FOR USE IN CLASS I, DIVISION 2, GROUPS A, B, C, D, OR NON-HAZARDOUS LOCATIONS ONLY

GENERAL SPECIFICATIONS

- POWER:** Derived from system backplane. (CSDIO draws 170 mA max. load on power input of MASTER). Modules may be hot-swapped (replaced while powered up) in non-hazardous locations only.
- LEDs:**
 - STS** - Status LED shows module condition.
 - IN1-IN8** - LEDs are lit when associated input is active.
 - OP1-OP6** - LEDs are lit when associated output is active.
 - ALM** - Alarm LED is lit when an internal alarm condition exists.
- MEMORY:** Non-volatile memory retains all programmable parameters. MASTER also stores the parameters in order to reprogram modules that are replaced.
- INPUTS:** DIP switch selectable for sink or source
Maximum voltage: +30 VDC, reverse polarity protected
Off Voltage: < 1.2 Volts
On Voltage: > 3.8 Volts
Input Impedance: Source Mode 10K ohms; Sink Mode 20K ohms
Input Frequency*:
Filter switch on: 50 Hz
Filter switch off: 300 Hz
* Actual useable frequency limited by communication to external device.
- OUTPUTS:** Outputs available as FORM-A relay or Solid State NFET.
Form A Relay Output:
Type: N.O.
The following pairs of relays share the common terminal: 1&2, 3&4, 5&6
Current Rating by pair: 3 Amps @ 30 VDC / 125 VAC resistive
1/10 HP @ 125 VAC
Life Expectancy: 200,000 cycles at maximum load rating. (Decreasing load, increasing cycle time, and use of surge suppression such as RC snubbers increases life expectancy.)
Solid State Output:
Type: Switched DC, N Channel open drain MOSFET
Contact Rating: 1 ADC max
VDS ON: < 0.2 V @ 1 A
VDS MAX: 30 VDC
Offstate Leakage Current: 0.5 μ A max
- LOGIC (BOOLEAN) MODE:**
Count Frequency: 200 Hz/input when input is directly connected (soft-wired) to the counter.
Logic Propagation Delay: 400 msecs. max.
Timer Accuracy: 0.2%
- ISOLATION LEVEL:** 500 Vrms @ 50/60 Hz for 1 minute between the following:
Inputs
Outputs
CS Master Power Supply Input
- COMMUNICATIONS:** Provided by the CS Master
- ENVIRONMENTAL CONDITIONS:**
Operating Temperature Range: 0 to +50°C
Storage Temperature Range: -40 to +85°C
Operating and Storage Humidity: 85% max relative humidity, non-condensing, from 0 to +50°C

Vibration According to IEC 68-2-6: Operational 10 to 150 Hz, 0.075 mm amplitude in X, Y, Z direction 1 g.
Shock According to IEC 68-2-27: Operational 25 g's (10 g's relay), 11 msec in 3 directions.

Altitude: Up to 2000 meters

10. CERTIFICATIONS AND COMPLIANCES:

SAFETY

UL Listed, File #E302106, UL508, CSA 22.2 No. 14-M05; File #E179259, UL61010-1, CAN/CSA-C22.2 No. 61010-1; and File #E317425, ANSI/ISA 12.12.01-2007, CSA 22.2 No. 213-M1987

LISTED by Und. Lab. Inc. to U.S. and Canadian safety standards IEC 61010-1, EN 61010-1: Safety requirements for electrical equipment for measurement, control, and laboratory use, Part 1.

ELECTROMAGNETIC COMPATIBILITY

Emissions and Immunity to EN 61326: 2006: Electrical Equipment for Measurement, Control and Laboratory use.

Immunity to Industrial Locations:

| | | |
|---------------------------|--------------|---|
| Electrostatic discharge | EN 61000-4-2 | Criterion B 4 kV contact discharge 8 kV air discharge |
| Electromagnetic RF fields | EN 61000-4-3 | Criterion A 10 V/m |
| Fast transients (burst) | EN 61000-4-4 | Criterion B power 2 kV I/O signal 1 kV I/O signal connected to power 2 kV |
| Surge | EN 61000-4-5 | Criterion B power 1 kV L-L, 2 kV L-G signal 1 kV |
| RF conducted interference | EN 61000-4-6 | Criterion A 3 V/rms |

Emissions:

| | | |
|-----------|----------|---------|
| Emissions | EN 55011 | Class A |
|-----------|----------|---------|

Notes:

- Criterion A: Normal operation within specified limits.
- Criterion B: Temporary loss of performance from which the unit self-recovers.
- Power supplied from back plane via Master Module.

11. **CONSTRUCTION:** Case body is burgundy high impact plastic. For indoor use only. Installation Category II, Pollution Degree 2.

12. **CONNECTIONS:** Removable wire clamp screw terminal blocks.

Wire Gage: 28-16 AWG terminal gage wire

Torque: 1.96-2.23 inch/lbs (0.22-0.25 N-m)

13. **MOUNTING:** Snaps on to standard DIN style top hat (T) profile mounting rails according to EN50022 -35 x 7.5 and -35 x 15.

14. **WEIGHT:** 6.6 oz (187.1 g)

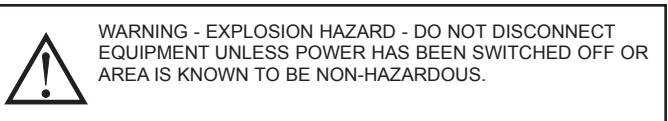

BLOCK DIAGRAM

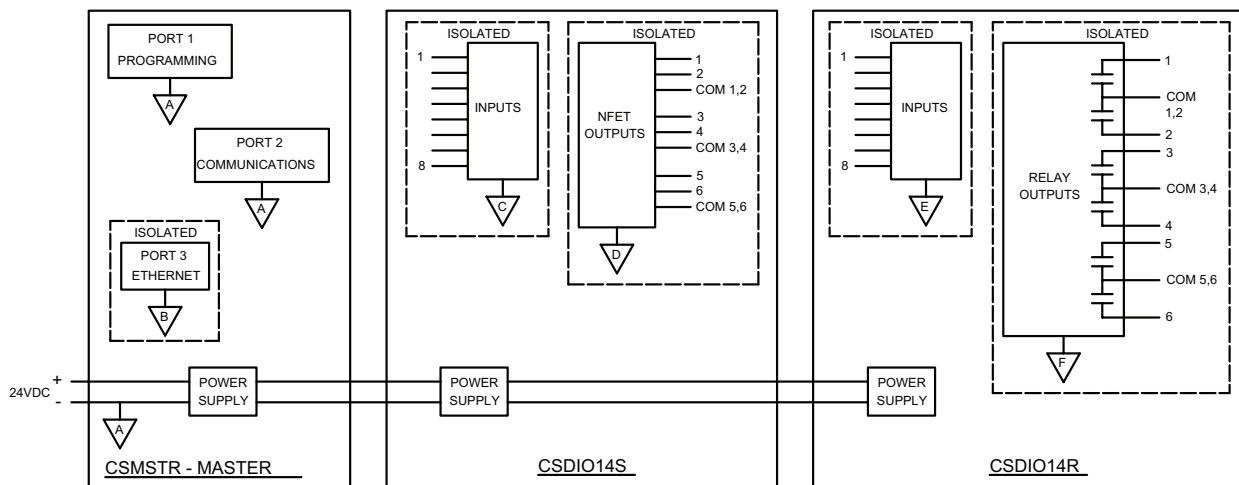

EMC INSTALLATION GUIDELINES

Although Monico Products are designed with a high degree of immunity to Electromagnetic Interference (EMI), proper installation and wiring methods must be followed to ensure compatibility in each application. The type of the electrical noise, source or coupling method into a unit may be different for various installations. Cable length, routing, and shield termination are very important and can mean the difference between a successful or troublesome installation. Listed are some EMI guidelines for a successful installation in an industrial environment.

1. A unit should be mounted in a metal enclosure, which is properly connected to protective earth.
 - a. The mounting clip that connects to the DIN rail should have the DIN rail connected to protective earth.
2. Use shielded (screened) cables for all Signal and Control inputs. The shield (screen) pigtail connection should be made as short as possible. The connection point for the shield depends somewhat upon the application. Listed below are the recommended methods of connecting the shield, in order of their effectiveness.
 - a. Connect the shield to earth ground (protective earth) at one end where the unit is mounted.
 - b. Connect the shield to earth ground at both ends of the cable, usually when the noise source frequency is over 1 MHz.
 - c. Connect the shield to common of the module and leave the other end of the shield unconnected and insulated from earth ground.
3. Never run Signal or Control cables in the same conduit or raceway with AC power lines, conductors, feeding motors, solenoids, SCR controls, and heaters, etc. The cables should be run through metal conduit that is properly grounded. This is especially useful in applications where cable runs are long and portable two-way radios are used in close proximity or if the installation is near a commercial radio transmitter. Also, Signal or Control cables within an enclosure should be routed as far away as possible from contactors, control relays, transformers, and other noisy components.
4. Long cable runs are more susceptible to EMI pickup than short cable runs. Therefore, keep cable runs as short as possible.

5. In extremely high EMI environments, the use of external EMI suppression devices such as Ferrite Suppression Cores for signal and control cables is effective. The following EMI suppression devices (or equivalent) are recommended:
 - Fair-Rite part number 0443167251
 - TDK part number ZCAT3035-1330A
 - Steward part number 28B2029-0A0

6. To protect relay contacts that control inductive loads and to minimize radiated and conducted noise (EMI), some type of contact protection network is normally installed across the load, the contacts or both. The most effective location is across the load.
 - a. Using a snubber, which is a resistor-capacitor (RC) network or metal oxide varistor (MOV) across an AC inductive load is very effective at reducing EMI and increasing relay contact life.
 - b. If a DC inductive load (such as a DC relay coil) is controlled by a transistor switch, care must be taken not to exceed the breakdown voltage of the transistor when the load is switched. One of the most effective ways is to place a diode across the inductive load. Most Monico products with solid state outputs have internal zener diode protection. However external diode protection at the load is always a good design practice to limit EMI. Although the use of a snubber or varistor could be used.

Note: Reference manufacturer's instructions when installing any EMI suppression device.

7. Also, care should be taken when connecting input and output devices to the instrument. When a separate input and output common is provided, they should not be mixed. Therefore a sensor common should NOT be connected to an output common. This would cause EMI on the sensitive input common, which could effect the instrument's operation.

HARDWARE INPUT SWITCHES

Each input is independently configurable for sinking or sourcing signals. A filter capacitor is also selectable for avoiding contact bounce.

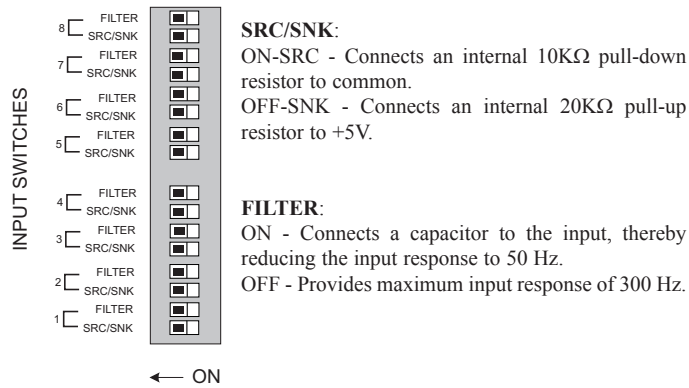

HARDWARE INSTALLATION

SEPARATE BASE FROM MODULE

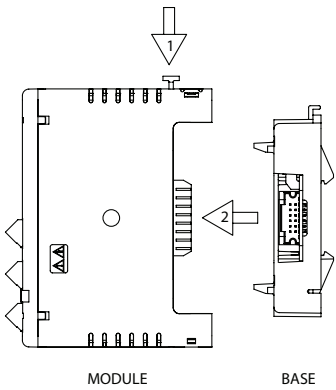

ATTACH THE MODULE BASE TO THE DIN RAIL

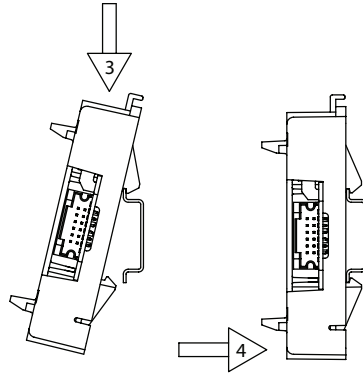

ATTACH MODULE TO BASE

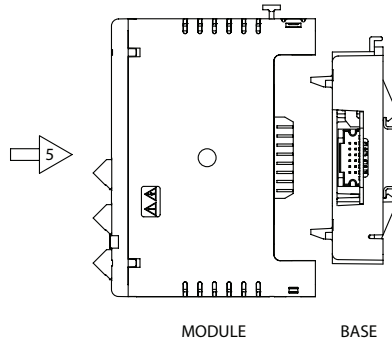

WIRING

WIRING CONNECTIONS

All conductors should meet voltage and current ratings for each terminal. Also, cabling should conform to appropriate standards of good installation, local codes and regulations. When wiring the module, use the numbers on the label to identify the position number with the proper function. Strip the wire, leaving approximately 1/4" (6 mm) of bare wire exposed. Insert the wire into the terminal, and tighten.

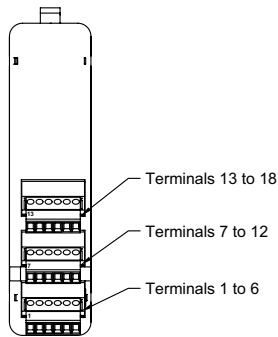

WARNING - EXPLOSION HAZARD - DO NOT DISCONNECT WHILE CIRCUIT IS ALIVE UNLESS AREA IS KNOWN TO BE NON-HAZARDOUS.

INPUT AND OUTPUT (I/O) WIRING MUST BE IN ACCORDANCE WITH CLASS I, DIV. 2 WIRING METHODS AND IN ACCORDANCE WITH THE AUTHORITY HAVING JURISDICTION.

INPUT CONNECTIONS

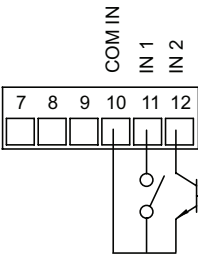
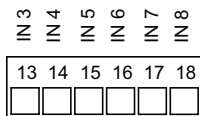
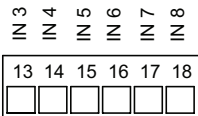

Sinking Input

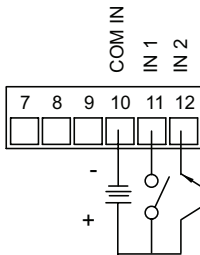

Sourcing Input

OUTPUT CONNECTIONS

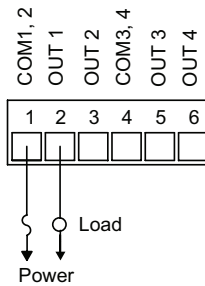
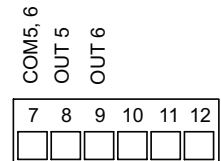
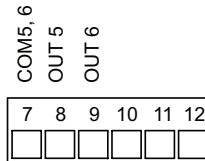

Relay Version

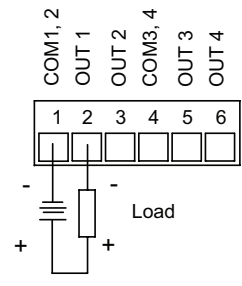

Solid State NFET Version

LEDS

STS – STATUS LED

The Status LED is a dual color LED that provides information regarding the state of the module. This includes indication of the various stages of the start-up routine (power-up), as well as any errors that may occur.

Startup Routine

| | |
|----------------------|---|
| Rapidly Flashing Red | Module is currently running the boot loader and/or being flash upgraded by Monico View. This occurs for four seconds during a power up. |
| Steady Red | Module switching to configuration. |
| Green | Module performing normally. |

Error States

| | |
|-------------------|---|
| Solid Red | Module not controlling, and not communicating. |
| Green/Pulsing Red | Module is controlling properly, but has lost communication with the Master. |

ALM – ALARM LED

The Alarm LED indicates the presence of a fault condition.

FIRMWARE UPGRADE

The module's firmware is stored in flash memory so that software/hardware conflicts are avoided, and so that software features may be added in the future.

During a download, Monico View compares its own library of firmware files with those stored in the Master module. If they do not match, Monico View will download the necessary files. The Master then checks to make sure that the I/O modules contain the same firmware. If they contain a different revision, the Master will automatically copy those files into the module's flash memory. During this process, the module LEDs will flash rapidly, starting with the top row, and progressing through the remaining rows until the process is complete.

CONFIGURATION

Programming is done via Monico View, a Windows® compatible configuration interface.

ORDERING INFORMATION

| TYPE | MODEL NO. | DESCRIPTION | PART NUMBER |
|-----------------|-----------|--|-------------|
| Digital Modules | CSDIO | Eight Inputs, Six Solid State Outputs | OEMDA022 |
| | | Eight Inputs, Six Relay Outputs For Non-Hazardous Locations Only | OEMDA027 |

This page intentionally left blank

This page intentionally left blank

LIMITED WARRANTY

The Company warrants the products it manufactures against defects in materials and workmanship for a period limited to two years from the date of shipment, provided the products have been stored, handled, installed, and used under proper conditions. The Company's liability under this limited warranty shall extend only to the repair or replacement of a defective product, at The Company's option. The Company disclaims all liability for any affirmation, promise or representation with respect to the products.

The customer agrees to hold Red Lion Controls harmless from, defend, and indemnify RLC against damages, claims, and expenses arising out of subsequent sales of RLC products or products containing components manufactured by RLC and based upon personal injuries, deaths, property damage, lost profits, and other matters which Buyer, its employees, or sub-contractors are or may be to any extent liable, including without limitation penalties imposed by the Consumer Product Safety Act (P.L. 92-573) and liability imposed upon any person pursuant to the Magnuson-Moss Warranty Act (P.L. 93-637), as now in effect or as amended hereafter.

No warranties expressed or implied are created with respect to The Company's products except those expressly contained herein. The Customer acknowledges the disclaimers and limitations contained herein and relies on no other warranties or affirmations.

Red Lion Controls
20 Willow Springs Circle
York PA 17406
Tel +1 (717) 767-6511
Fax +1 (717) 764-0839

Monico Monitoring, Inc.
3403 Chapel Square Dr.
Spring TX 77388
Tel +1 (281) 350-8751
Fax +1 (281) 754-4633